

User Manual

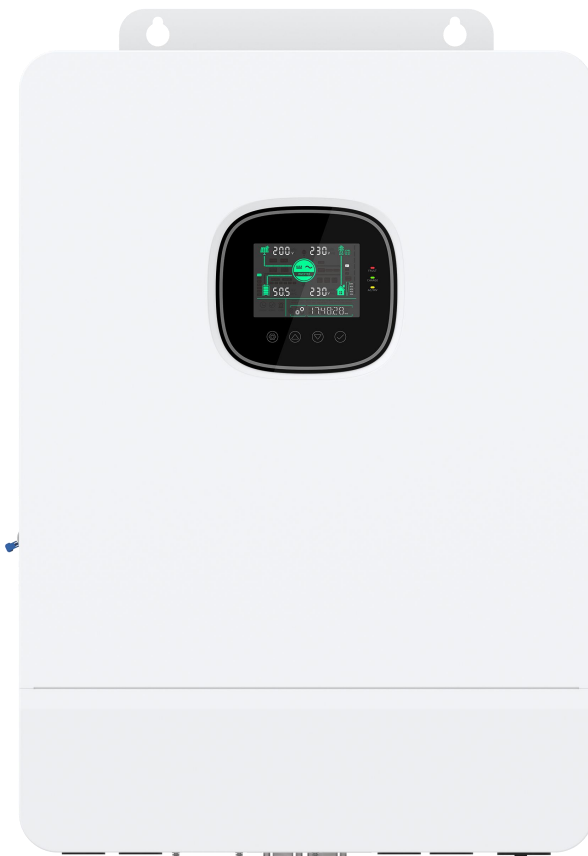

All-in-one solar charge inverter

SPI-8K-UP

SPI-10K-UP

Contents

1. Safety	1
1.1 About this Manual	1
1.2 Symbols and description	1
1.3 Safety matters	1
2. About the Product	2
2.1 Description	2
2.2 Features	2
2.3 System connection diagram	3
2.4 Product overview	4
3. Installation	5
3.1 Installation location	5
3.2 Inverter installation	6
3.3 Removal of terminal cover and insect-proof net	6
4. Wiring	7
4.1 Wiring mode (depends on the output mode)	7
4.2 Cable and circuit breaker model	10
4.3 AC input and output wiring	12
4.4 Battery wiring	12
4.5 PV wiring	13
4.6 Dry contact wiring	13
4.7 Grounding	14
4.8 Inverter start	14
4.9 Parallel wiring	14
4.9.1 Parallel operation	14
4.9.2 Cautions for parallel connection	15
4.9.3 Wiring diagram for single-phase parallel connection (phase difference between L1 and L2: 0°)	16
4.9.4 Wiring diagram for two-phase parallel connection (phase difference between L1 and L2: 0°)	19
4.9.5 Wiring diagram for split-phase parallel connection (phase difference between L1 and L2: 180°)	24
4.9.6 Wiring diagram for three-phase parallel connection	26
5. Operation	31
5.1 Operation and display panel	31
5.2 Setting	35
5.3 AC output mode	41
5.4 Battery charge mode	43
5.5 Timed charge/discharge function	43
5.6 Battery parameters	44





6. Communication	46
6.1 Overview	46
6.2 USB-B port	46
6.4 RS485/CAN port	47
6.5 Dry contact port	48
7. Fault Codes and Response Measures	49
7.1 Fault codes	49
7.2 Troubleshooting	51
8. Protection Function and Product Maintenance	52
8.1 Protection function	52
8.2 Maintenance	54
9. Parameter Table	55

1. Safety

1.1 About this Manual

- This Manual contains important information, guiding principles, operation, and maintenance of the product, and applies to the model: SPI UP series.
- Users must follow the instructions in this Manual during installation, use, and maintenance.

1.2 Symbols and description

Symbol	Description
 DANGER	Dangerous situations that will lead to death or serious injury when ignored.
 WARNING	Dangerous situations that may lead to death or serious injury when ignored.
 CAUTION	Dangerous situations that may lead to mild or moderate injury when ignored.
 NOTICE	Operation tips.

1.3 Safety matters

DANGER

- This chapter contains important safety matters. Please read and keep this Manual for future reference.
- Please make sure to comply with local requirements and regulations when installing the inverter.
- Be careful of high voltage. Before and during installation, please turn off the switch of each power supply to avoid electric shock.
- In order to achieve optimal operation of the inverter, please select the appropriate cable size and necessary protective devices according to regulations.
- Do not connect or disconnect any connections when the inverter is working.
- Do not open the terminal cover when the inverter is working.
- Keep the inverter well-grounded.
- Avoid short circuits in AC output and DC input.
- Do not disassemble the inverter. Send the inverter to a professional service center for repair and maintenance.
- Do not charge frozen batteries.

2. About the Product

2.1 Description

SPI series is a new type of solar storage inverter that integrates PV storage, mains charge, and energy storage and outputs sinusoidal AC. Equipped with DSP control and advanced control algorithm, it has high response speed and good reliability, and applies to industrial scenarios.

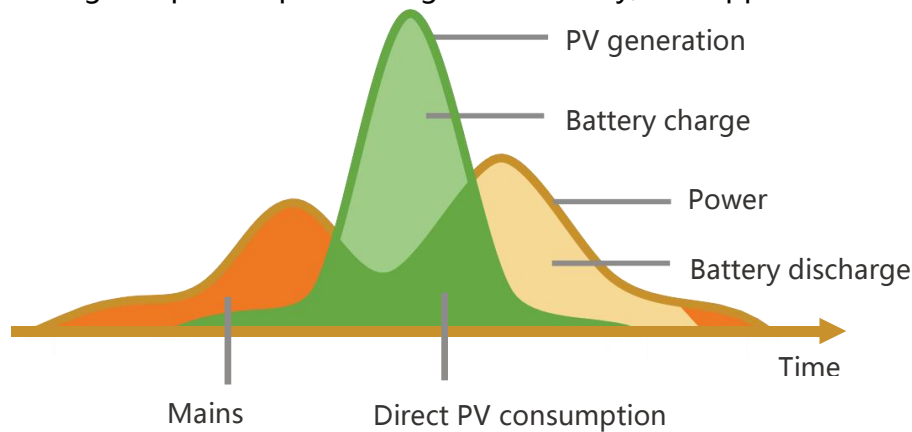

2.2 Features

- Support the connection of various types of energy storage batteries such as lead-acid battery and lithium-ion battery
- Have the dual activation function during lithium-ion battery sleep, that is, access to mains/PV power can activate the lithium-ion battery
- Support split-phase/single-phase pure sine wave output
- Support adjusting the voltage of each phase within the range of 100 VAC, 105 VAC, 110 VAC, 115 VAC, 120VAC, 127VAC
- Support two-channel PV input and have the function of simultaneous two-channel Max. power point tracking (MPPT) for charging/carrying capacity
- Support two-channel MPPT, with an efficiency of up to 99.9% and a maximum single-channel current of 22 A, perfectly fitting high-power modules
- Provide four charge modes: only PV, mains first, PV first, and mains + PV
- Have the timed charge and discharge function, that is, users can set the charge and discharge time according to the time-of-use price to save electricity costs
- Have the energy-saving mode, reducing no-load energy losses
- Provide two output modes: mains bypass output and inverter output, achieving uninterrupted power supply
- Support LCD display of dynamic flowchart, updating system data and operating status at any time
- Provide 360 ° protection, including short circuit protection, overcurrent protection, overvoltage and undervoltage protection, and overload protection
- Support CAN, USB, RS485 communication

2.3 System connection diagram

The following figure shows the system application scenario of the product. A complete system consists of the following parts:

1. **PV module:** It converts solar energy into DC to charge batteries or into AC to supply power to loads.
 2. **Mains or generator:** Connected to AC input, it can charge batteries while supplying power to loads. When the battery and PV module supply power to the load, the system can generally operate without mains or generator.
 3. **Battery:** The function of a battery is to ensure normal power supply for the system load when there is insufficient PV power and no mains.
 4. **Household load:** It can connect various household and office loads, including refrigerators, lighting fixtures, TVs, fans, air conditioners, and other AC loads.
 5. **Inverter:** It is the energy conversion device of the entire system.
- **The actual application scenario determines the specific system wiring mode**

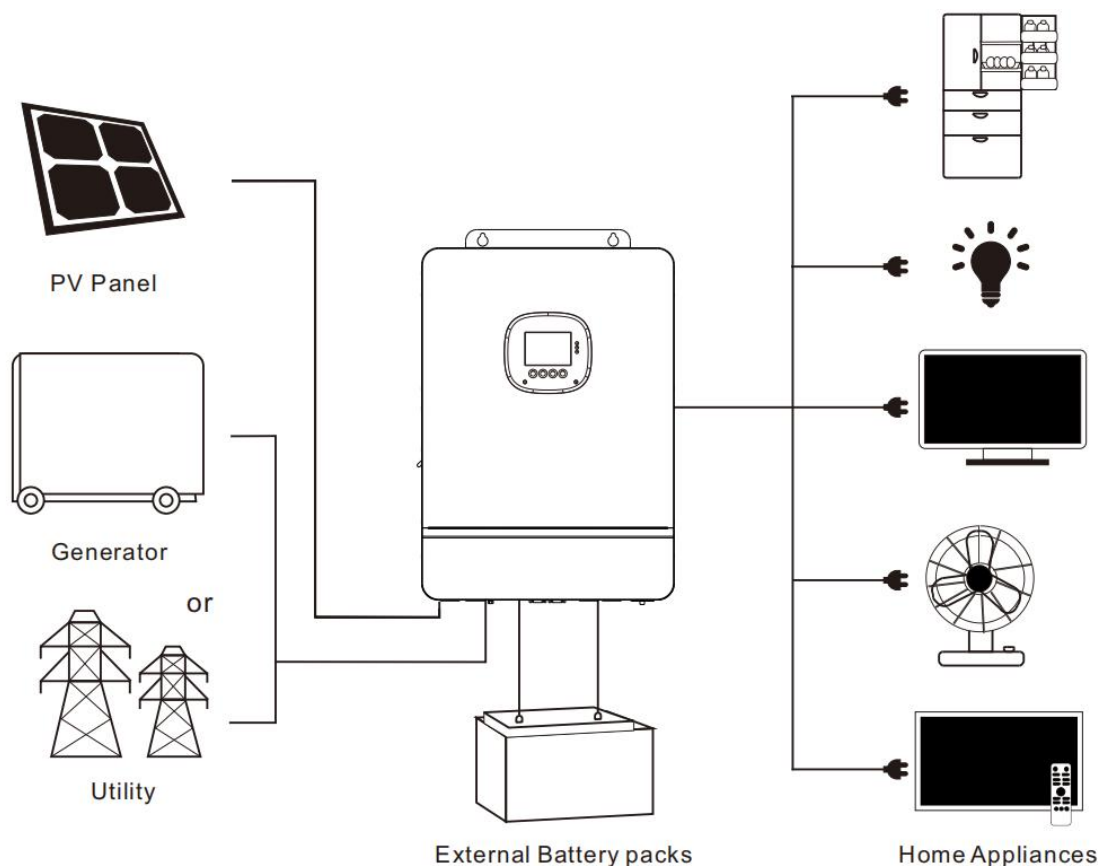

2.4 Product overview

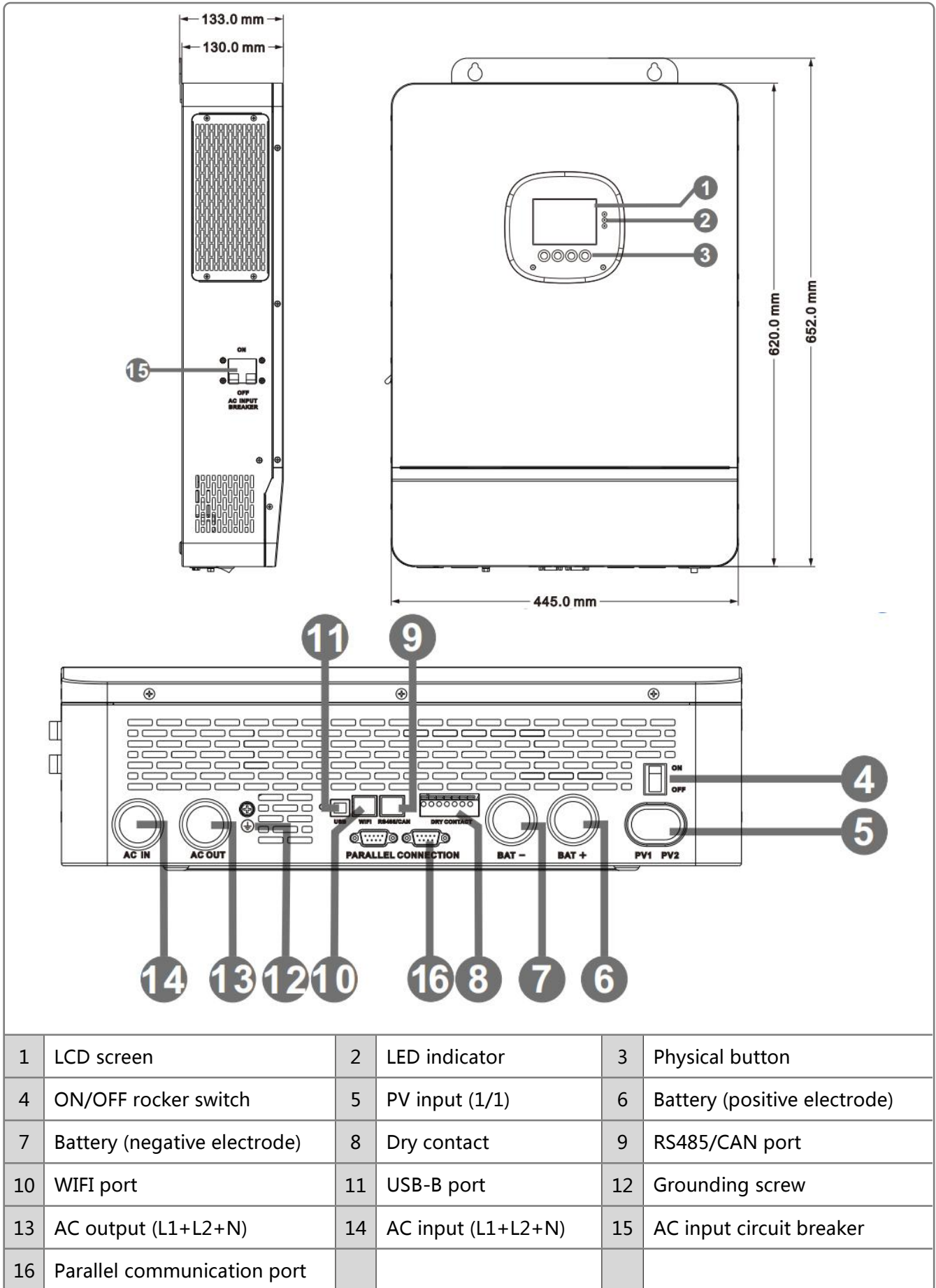

3. Installation

3.1 Installation location

SPI series is only for indoor use (**protection level: IP20**). Before selecting the installation location, users should consider the following factors:

- A solid wall
- Installation height: flush with the line of sight
- Sufficient heat dissipation space
- Ambient temperature: -10°C – 55°C (14°F – 131°F), to ensure optimal operation

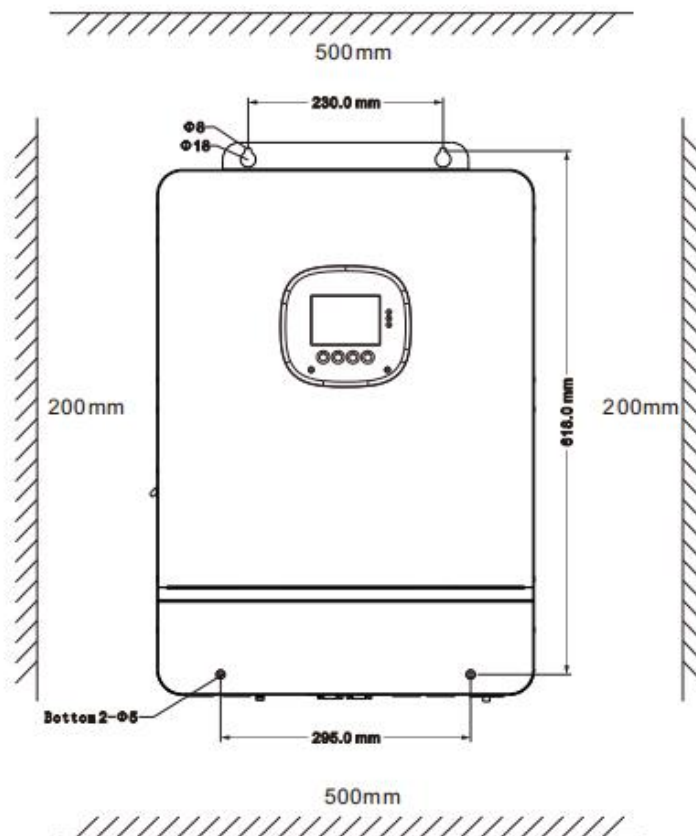

DANGER

- Do not install the inverter near highly flammable materials
- Do not install the inverter in potentially explosive areas
- Do not install the inverter and lead-acid battery in enclosed spaces

CAUTION

- Do not install the inverter in direct sunlight
- Do not install or use the inverter in damp environments

3.2 Inverter installation

Drill 4 installation holes of the specified sizes on the wall with an electric drill, insert 2 expansion screws above, and fix the inverter with 2 M5 screws below.

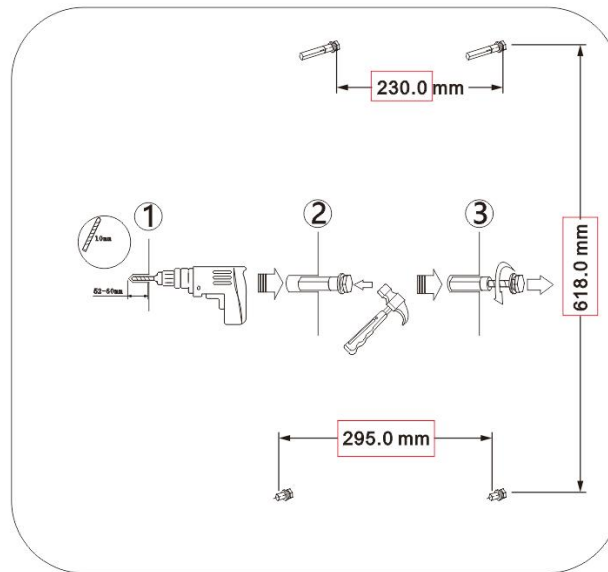

3.3 Removal of terminal cover and insect-proof net

Remove the terminal cover and insect-proof net with a screwdriver

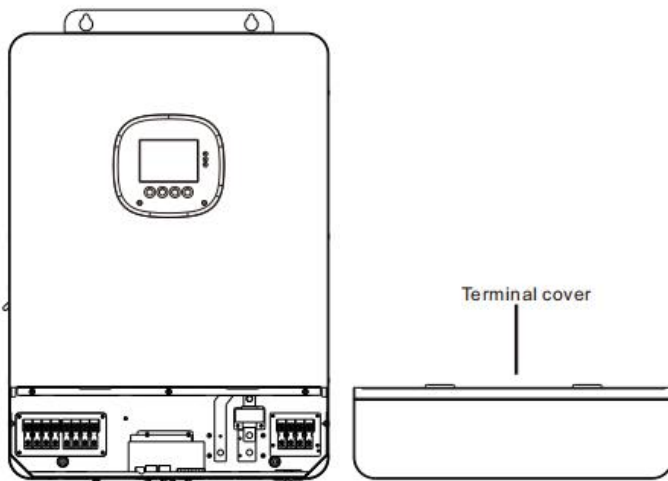

Remove the insect-proof net when cleaning

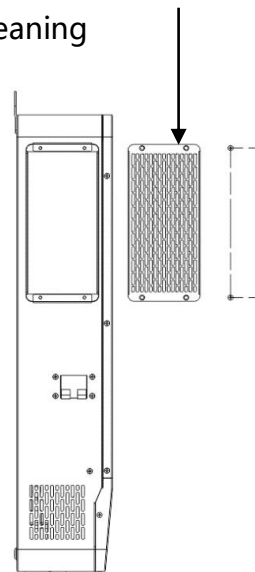

① NOTICE

- When using the inverter in areas with poor air quality, the dustproof net is easily blocked by air particles. Please regularly remove and clean it to avoid affecting the air flow rate inside the inverter; otherwise it may cause inverter overheating (19/20 fault), and affect power supply and the service life of the inverter

4. Wiring

4.1 Wiring mode (depends on the output mode)

- Split-phase mode (default)

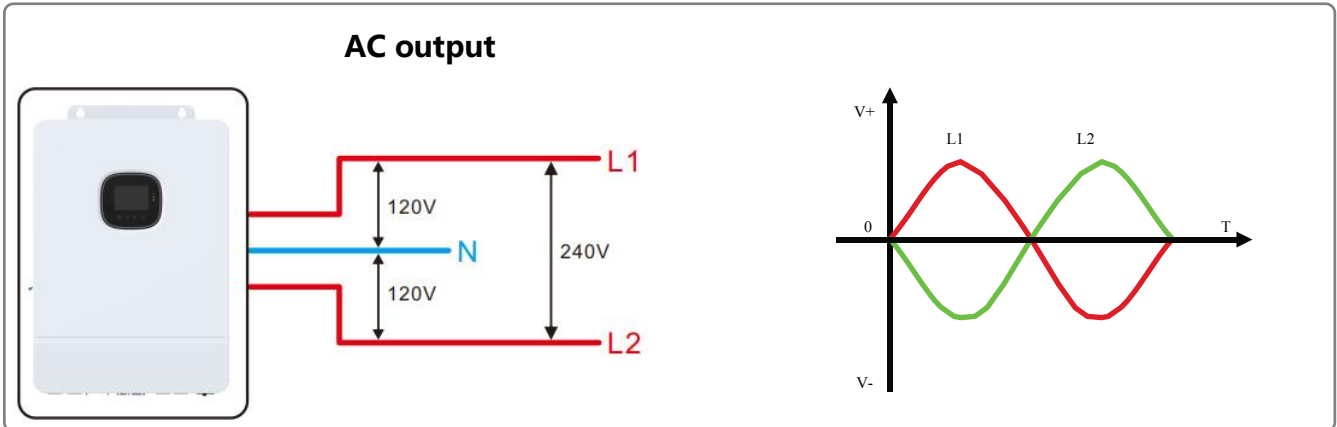

Item	Description
Applicable model	SPI series U model
AC output phase voltage (L-N)	100 VAC–120 VAC, 120 VAC (default)
AC output line voltage (L-L)	200 VAC–240 VAC, 240 VAC (default)

- Single-phase mode

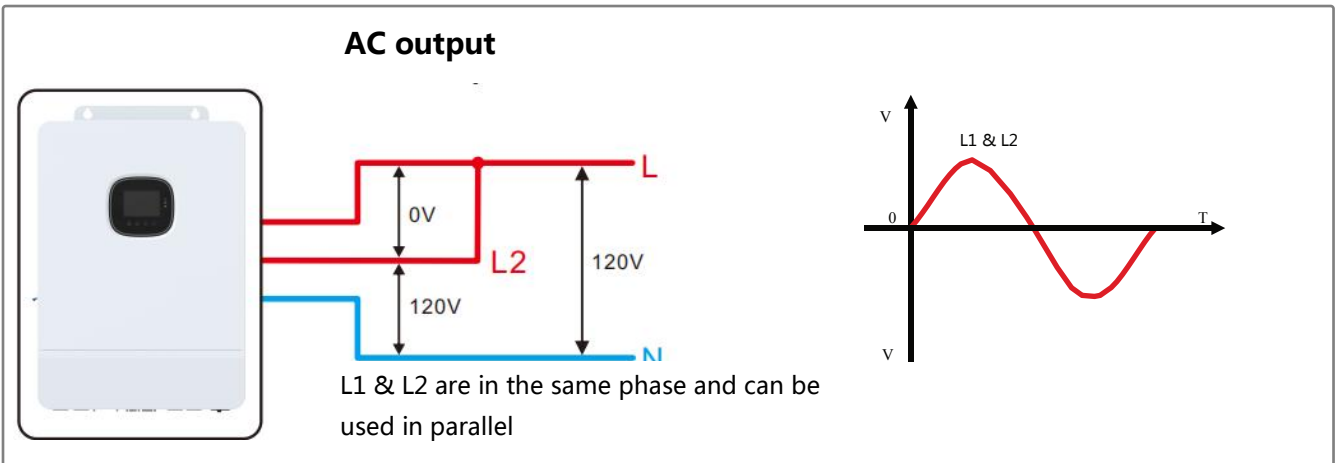

Item	Description
Applicable model	SPI series U model
AC output phase voltage (L-N)	100 VAC–120 VAC, 120 VAC (default)

Split-phase Mode

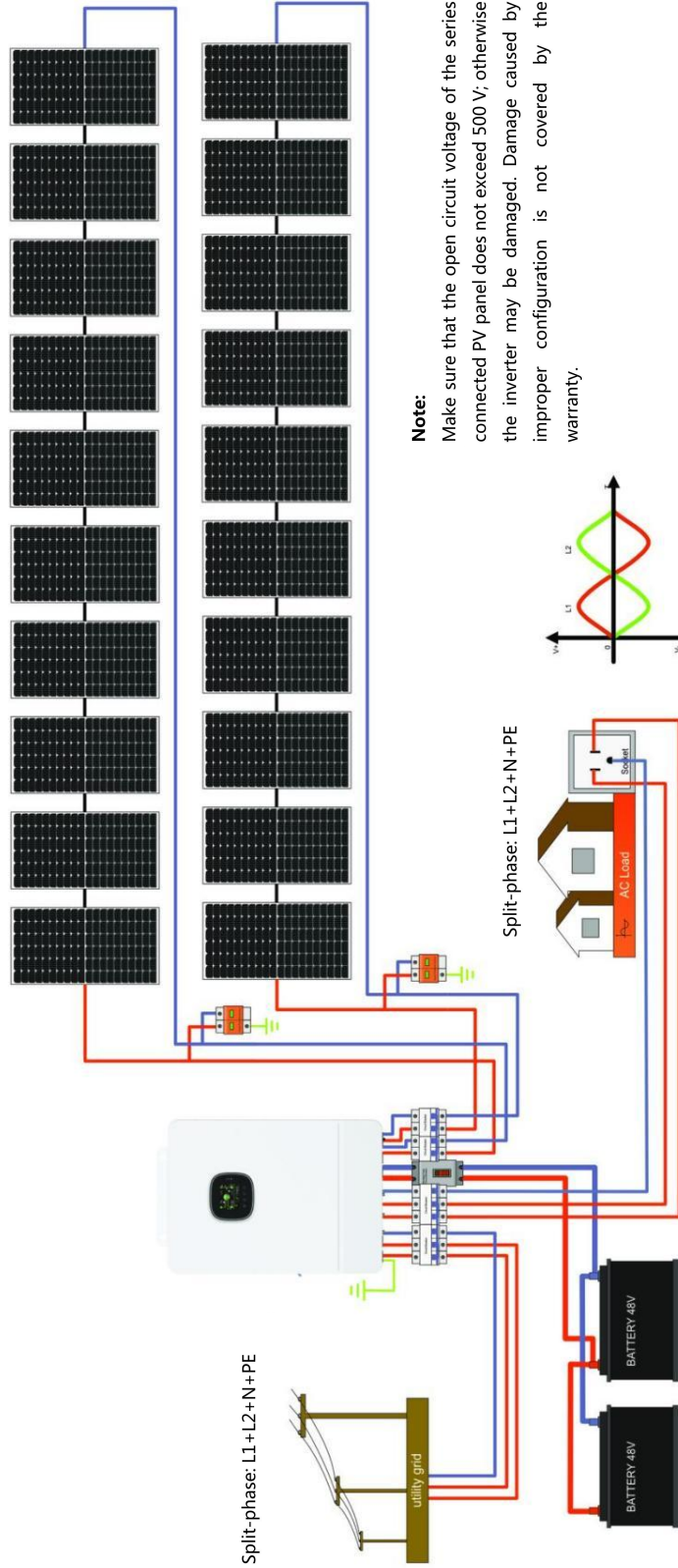

Single-phase mode

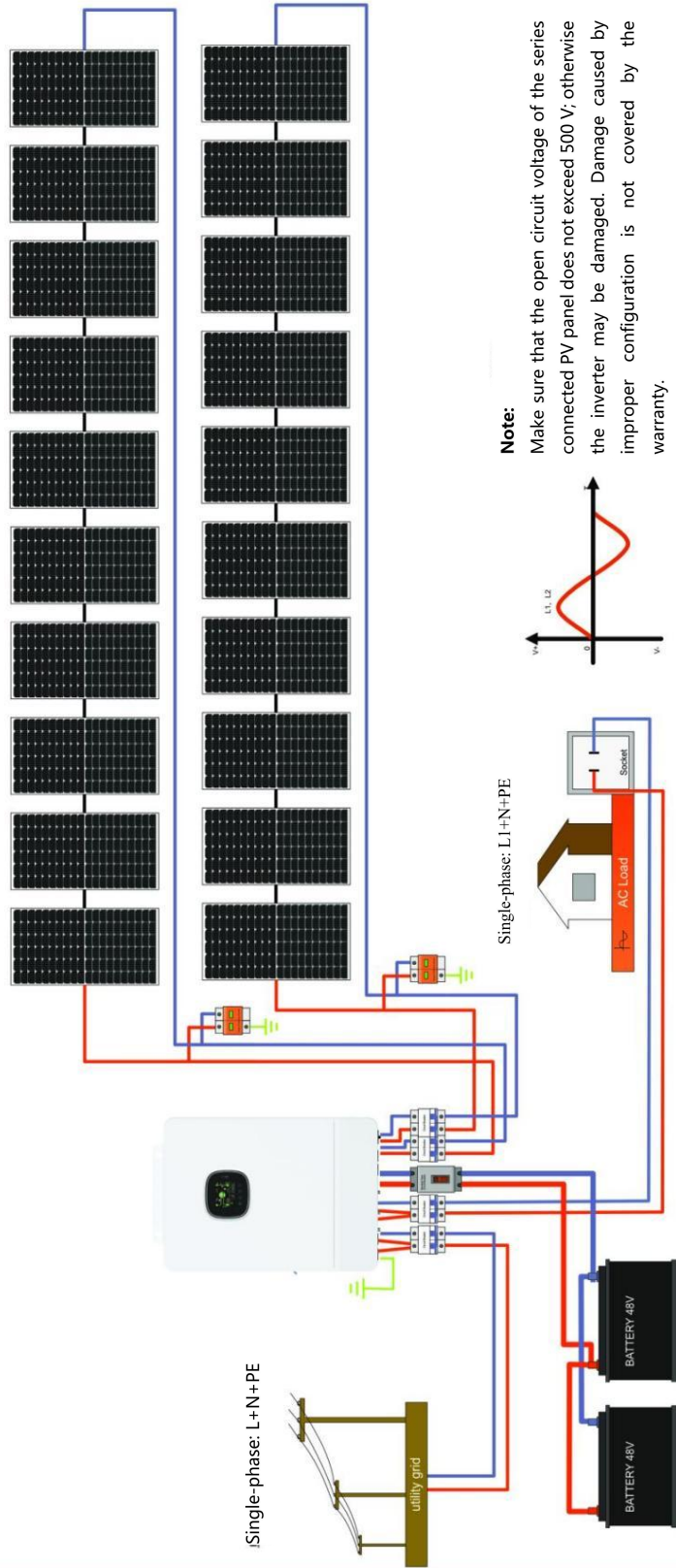

4.2 Cable and circuit breaker model

- PV INPUT**

Inverters Models	Cable Size	Max. Input Current	Circuit Breaker Model
SPI-8K-UP	4 mm ² /12 AWG	22A	2P-25A
SPI-10K-UP	4 mm ² /12 AWG	22A	2P-25A



- Battery**

Inverter Models	Cable Size	Max. Current	Circuit Breaker Model
SPI-8K-UP	50 mm ² /0 AWG	180A	2P-200A
SPI-10K-UP	70 mm ² /00 AWG	220A	2P-250A

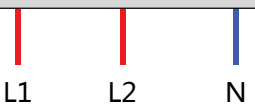
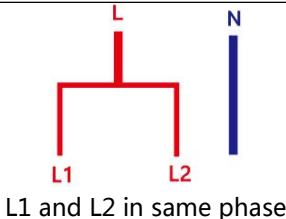
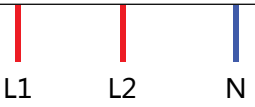
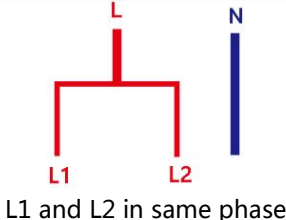
- AC INPUT**

Inverter Models	Output Mode	Diagram	Max. Current	Cable Size	Circuit Breaker Model
SPI-8K-UP	Split-phase mode	 <p>L1 L2 N</p>	63A (L1/L2/N)	13mm ² /6 AWG (L1\L2\N)	3P-63A
	Single-phase mode	 <p>L1 and L2 in same phase</p>	63A (L1/L2) 126 A (N)	13mm ² /6 AWG (L1/L2) 26 mm ² /3 AWG (N)	2P-125A
SPI-10K-UP	Split-phase mode	 <p>L1 L2 N</p>	63A (L1/L2/N)	13mm ² /6 AWG (L1\L2\N)	3P-63A
	Single-phase mode	 <p>L1 and L2 in same phase</p>	63A (L1/L2) 126A (N)	13mm ² /6 AWG (L1/L2) 26mm ² /3 AWG (N)	2P-125A

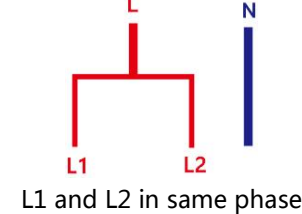
• **AC output**

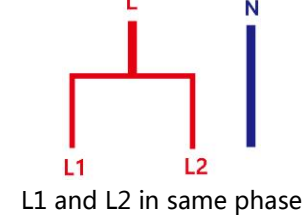
Inverter Models	Output Mode	Diagram	Max. Current	Cable Size	Circuit Breaker Model
SPI-8K-UP	Split-phase mode		42A (L1/L2/N)	13mm ² /6 AWG (L1\L2\N)	3P-63A
	Single-phase mode		42A (L1/L2) 84 A (N)	13mm ² /6 AWG (L1\L2) 26mm ² /3 AWG (N)	2P-125A
SPI-10K-UP	Split-phase mode		63A (L1/L2/N)	13mm ² /6 AWG (L1\L2\N)	3P-63A
	Single-phase mode		63A (L1/L2) 126 A (N)	13mm ² /6 AWG (L1\L2) 26mm ² /3 AWG (N)	2P-125A

ⓘ **NOTICE**

• **PV input, AC input, and AC output terminals**

1. Use a wire stripper to strip off 6 mm–8 mm long insulation layer of the cable.
2. Fix a sleeve at the end of the cable (the sleeve is to be prepared by the user)

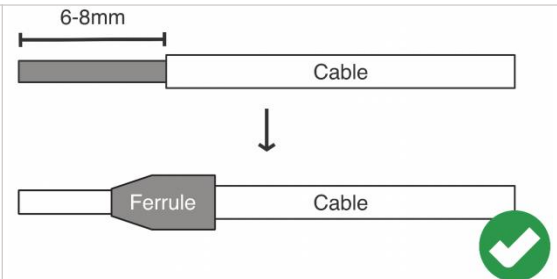

• **Battery terminal**

1. Use a wire stripper to strip off 6 mm–8 mm long insulation layer of the cable.
2. Fix a ring terminal (attached) at the end of the cable

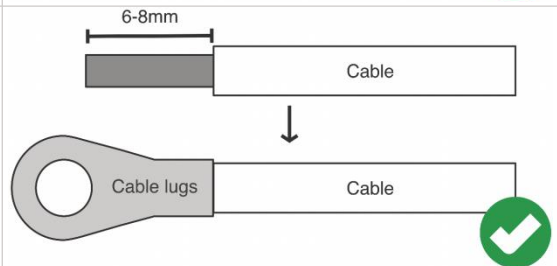

The cable size is for reference only. If the distance between the PV array and the inverter or between the inverter and the battery is long, using thicker cables will reduce voltage drop and improve system performance.

4.3 AC input and output wiring

Connect the live wire, neutral wire, and ground wire according to the cable position and sequence shown in the following figure.

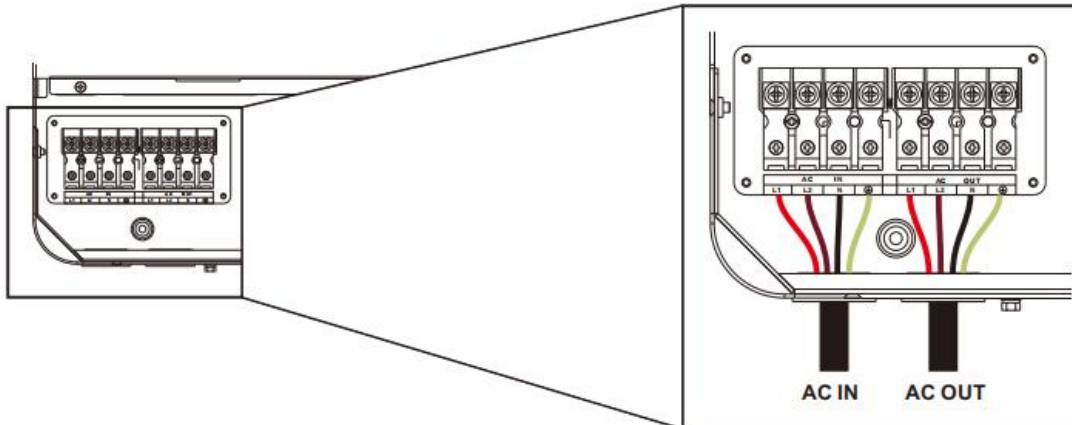

⚠ DANGER

- Before connecting AC input and output, be sure to disconnect the circuit breaker to avoid the risk of electric shock. Do not conduct live operation.
- Please check whether the cables used are sufficient to meet the requirements. Cables that are too thin or of poor quality may pose serious safety hazards.

4.4 Battery wiring

Connect the positive and negative cables of the battery according to the cable position and sequence shown in the following figure.

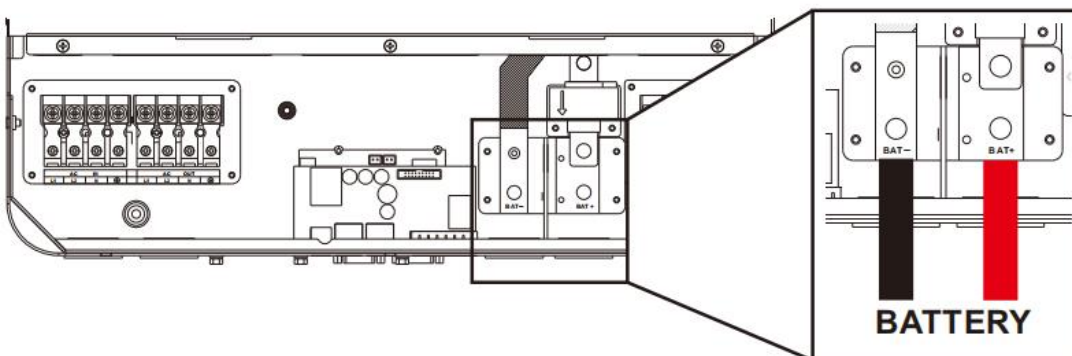

⚠ DANGER

- Before connecting the battery, be sure to disconnect the circuit breaker to avoid the risk of electric shock. Do not conduct live operation.
- Please check the positive and negative terminals of the battery for correct connection and no reverse connection; otherwise it may damage the inverter.
- Please check whether the cables used are sufficient to meet the requirements. Cables that are too thin or of poor quality may pose serious safety hazards.

4.5 PV wiring

Connect the positive and negative terminals of the two-channel PV modules according to the cable position and sequence shown in the following figure.

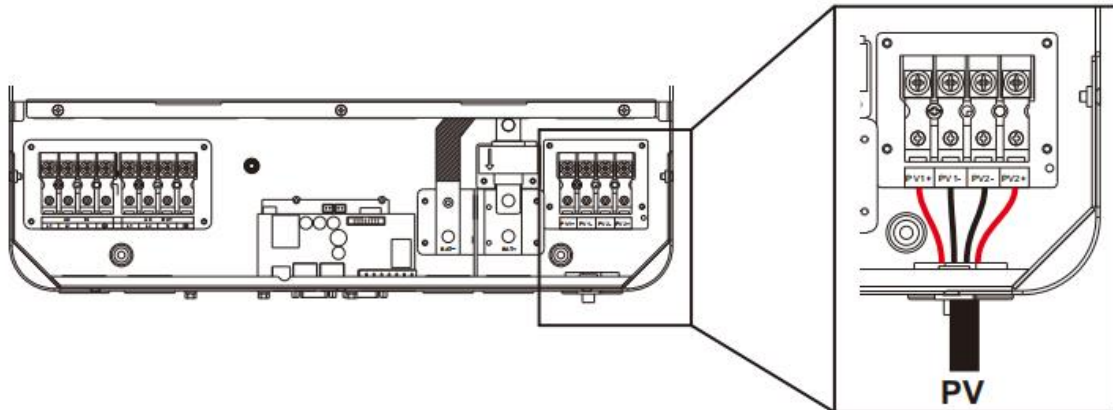

⚠ DANGER

- Before connecting PV modules, be sure to disconnect the circuit breaker to avoid the risk of electric shock. Do not conduct live operation.
- Please make sure that the open circuit voltage of the series connected PV modules does not exceed the maximum open circuit voltage of the inverter (in ASP series, this value is 500 V); otherwise the inverter may be damaged.

4.6 Dry contact wiring

Use a small-sized screwdriver to push back in the direction indicated by the arrow, and then insert the communication cable into the dry contact port. (Communication cable section: 0.2 mm²–1.5 mm²).

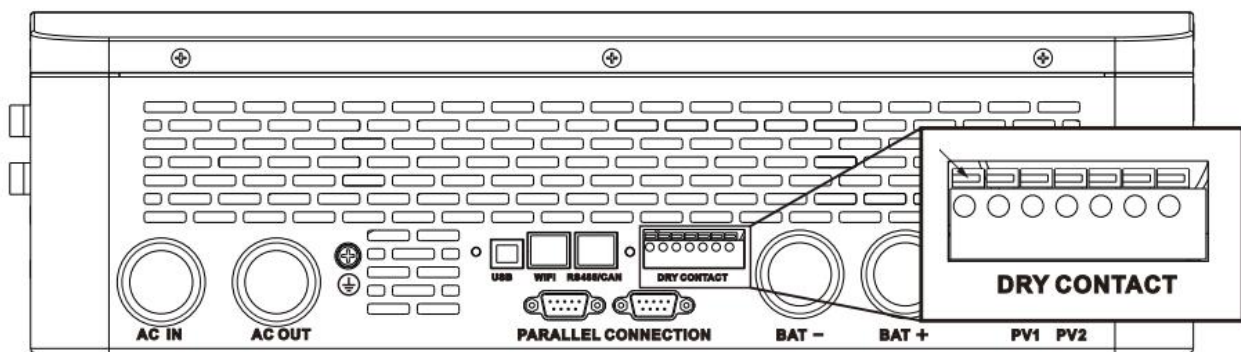

4.7 Grounding

Please ensure that the grounding terminal is reliably connected to the grounding busbar.

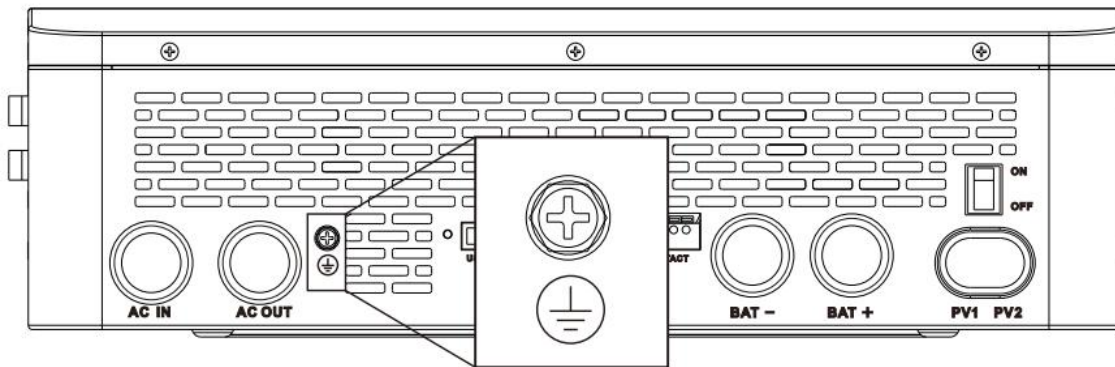

ⓘ NOTICE

- The grounding cable size shall not be less than 4 mm² and shall be as close as possible to the grounding point.

4.8 Inverter start

After confirming reliable wiring and correct wiring sequence, restore the terminal cover to its original position.

- Step 1: Close the circuit breaker of the battery
- Step 2: Press the rocker switch at the bottom of the inverter, and the screen and indicator will light up, indicating that the inverter is enabled
- Step 3: Close the circuit breakers for PV input, AC input, and AC output in sequence
- Step 4: Start loads one by one in order of power from small to large

4.9 Parallel wiring

4.9.1 Parallel operation

1. The parallel operation supports up to six solar storage inverters.
2. When using the parallel function, it is necessary to connect the parallel communication cable in a correct and reliable manner. See the figure below for the communication cable (packaging accessory):

Parallel communication cable*1

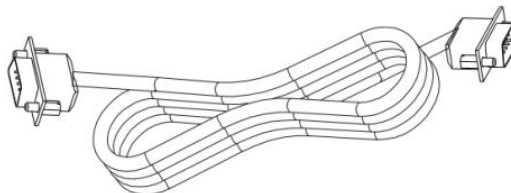

4.9.2 Cautions for parallel connection



Warning:

1. PV wiring:

In parallel connection, the PV array of each inverter must be independent, and the PV array of PV1 and PV2 for one inverter must also be independent.

2. Battery wiring

In single-phase or three-phase parallel connection, all solar storage inverters must be connected to the same battery, with BAT+ connected to BAT+ and BAT- to BAT-, and before power on and start-up, it is necessary to check and ensure correct connection, wiring length, and cable size, so as to avoid the abnormal operation of parallel system output caused by wrong connection.

3. AC OUT wiring:

In single-phase parallel connection, all solar storage inverters must be connected in the manner of L-to-L, N-to-N, and PE-to-PE, and before power on and start-up, it is necessary to check and ensure correct connection, wiring length, and cable size, so as to avoid the abnormal operation of parallel system output caused by wrong connection.

In three-phase parallel connection, all solar storage inverters must be connected in the manner of N-to-N and PE-to-PE. The L lines of all inverters in the same phase shall be connected together, but the AC output L lines of different phases shall not be connected together. Other cautions are the same as those for single-phase parallel connection.

4. AC IN wiring:

In single-phase parallel connection, all solar storage inverters must be connected in the manner of L-to-L, N-to-N, and PE-to-PE, and before power on and start-up, it is necessary to check and ensure correct connection, wiring length, and cable size, so as to avoid the abnormal operation of parallel system output caused by wrong connection. Meanwhile, it is not allowed to have multiple different AC source inputs to avoid damage to the external equipment of the inverter. The AC source input shall be consistent and unique.

In three-phase parallel connection, all solar storage inverters must be connected in the manner of N-to-N and PE-to-PE. The L lines of all inverters in the same phase shall be connected together, but the AC output L lines of different phases shall not be connected together. Other cautions are the same as those for single-phase parallel connection.

5. Communication wiring:

Our company's communication cable for parallel operation is a DB15 standard computer cable with shielding function, and it is used for single-phase or three-phase parallel connection. Each inverter shall be connected with one out and one in, that is, the male

connector (out) of the inverter is to be connected to the female connector (in) of the parallel inverter, not the one of the inverter. In addition, DB15 terminal screws will be used to tighten the communication cable of each parallel inverter to avoid falling off or poor contact of the communication cable, followed by abnormal operation or damage of the system output.

6. Before and after connecting the system, please carefully refer to the following system wiring diagrams to ensure that all wiring is correct and reliable before power on.
7. After the system is correctly wired, powered on, and in normal operation, if a new inverter needs to be connected, make sure to disconnect the battery input, PV input, AC input and AC output, and that all solar storage inverters are powered off before reconnecting into the system.

4.9.3 Wiring diagram for single-phase parallel connection (phase difference between L1 and L2: 0°)

- The communication cable of parallel solar storage inverter is to be locked with screws after connecting. See the diagram below:

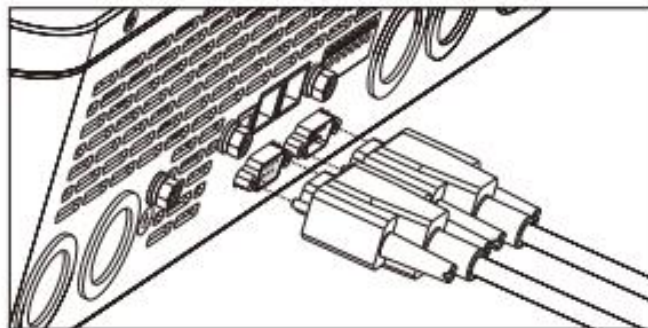

- See the diagram below for parallel connection

Set the item [31] to "PAL" and the item [68] to "0°." When setting the item [38] to "120 V," the output L-N voltage is 120 V

1. Two parallel-connected solar storage inverters:

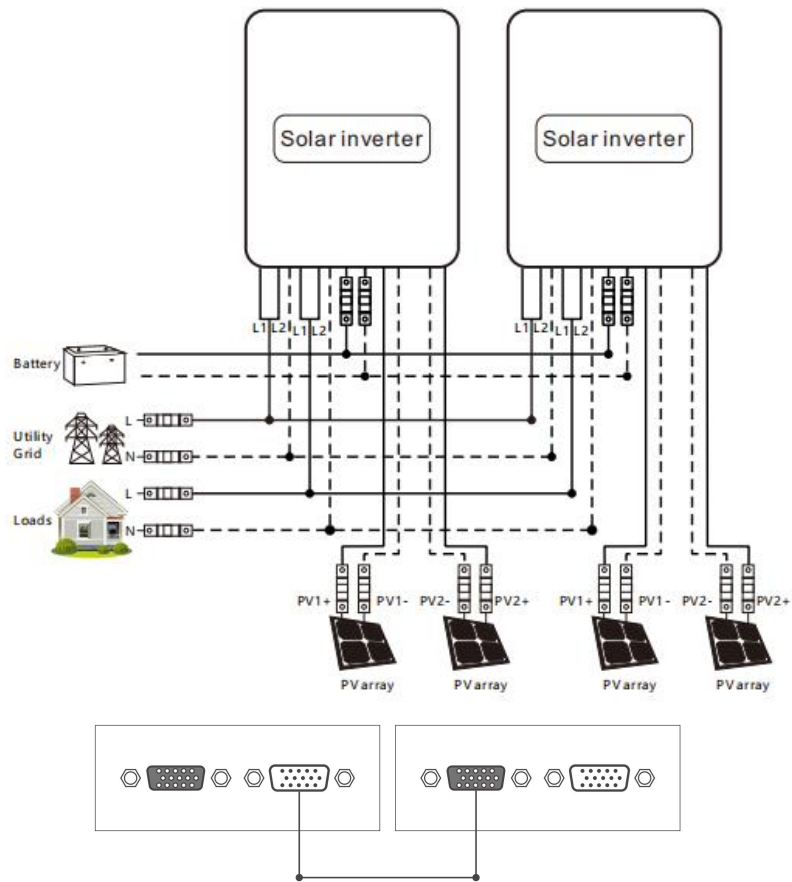

2. Three parallel-connected solar storage inverters:

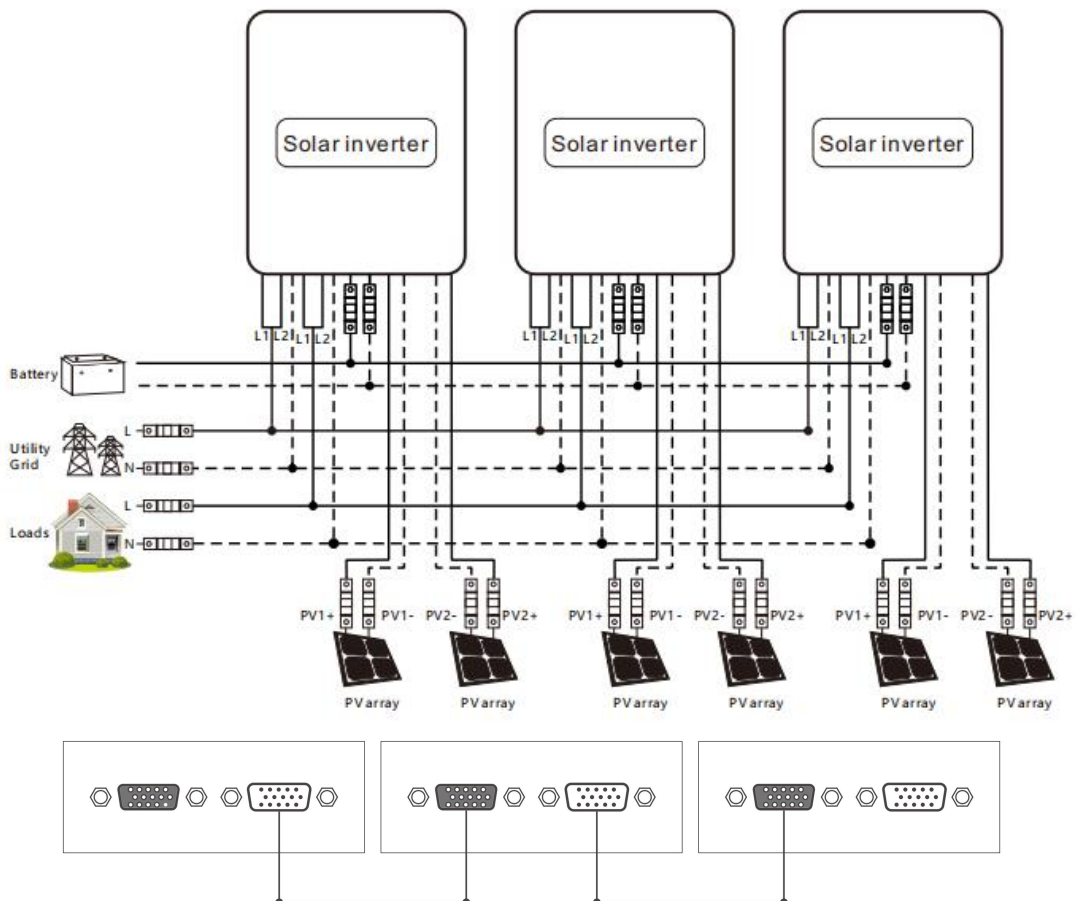

3. Four parallel-connected solar storage inverters:

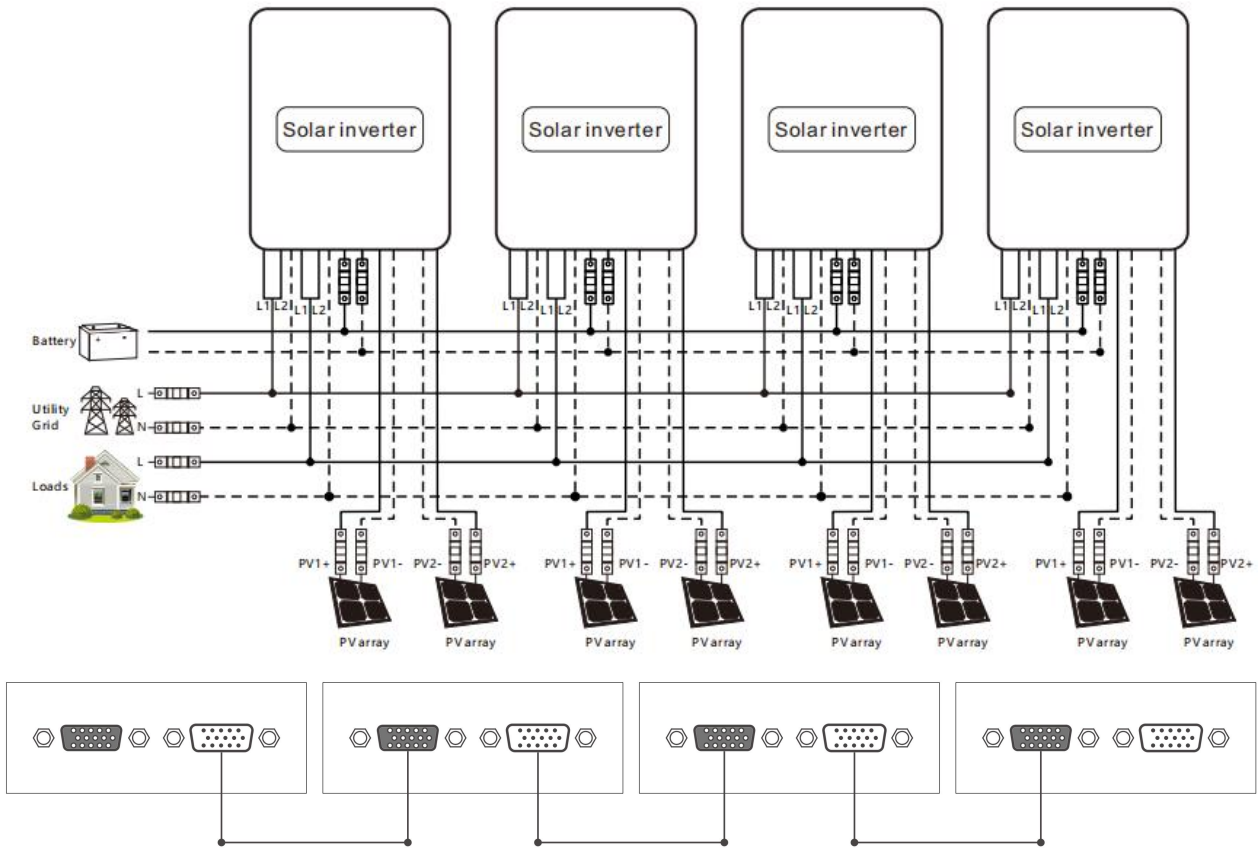

4. Five parallel-connected solar storage inverters:

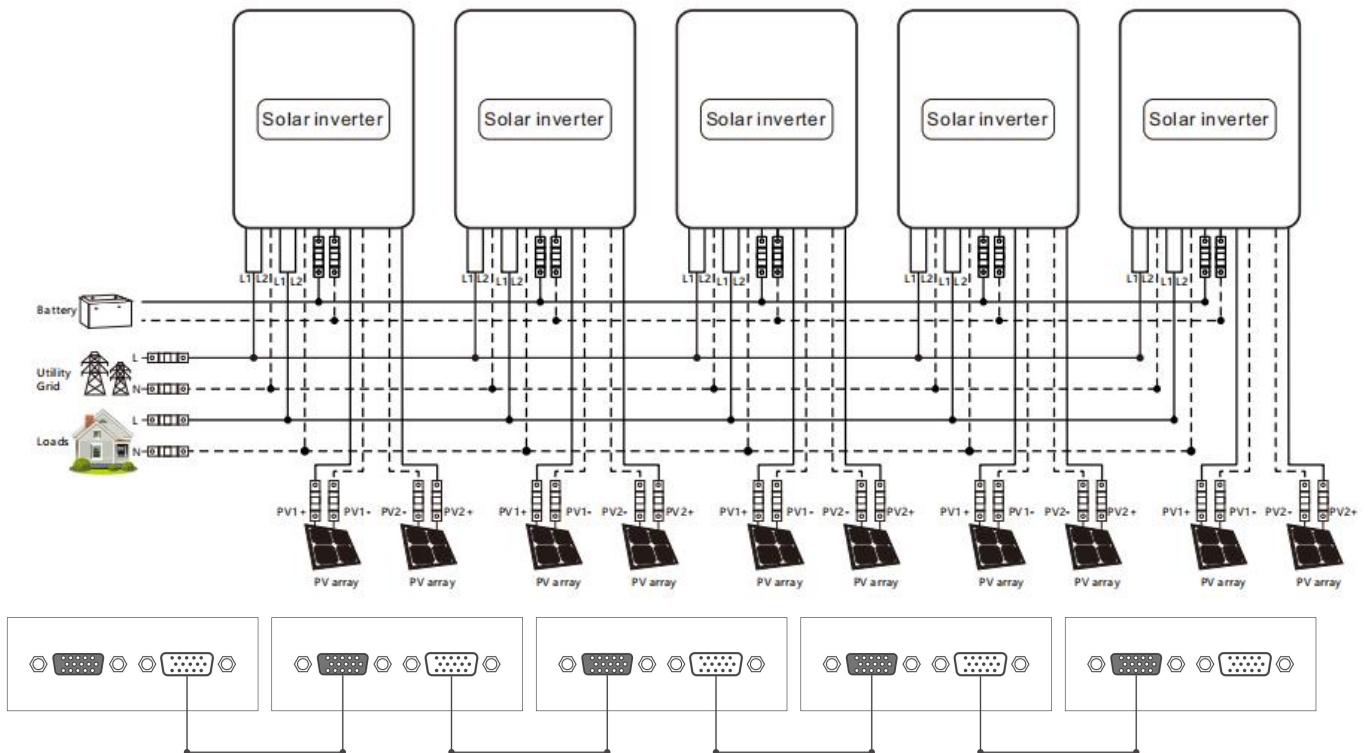

5. **Six parallel-connected solar storage inverters:**

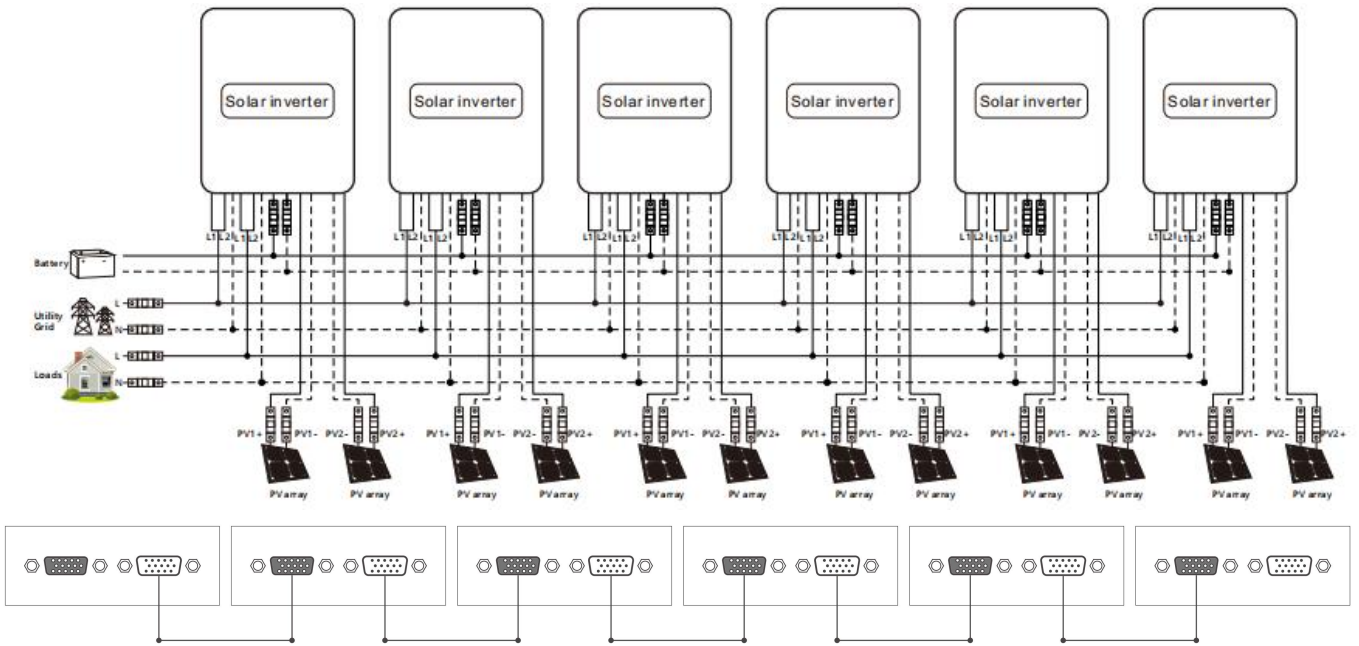

4.9.4 Wiring diagram for two-phase parallel connection (phase difference between L1 and L2: 0°)

- (1) P1: Set the item [31] to "2P0;" P2: Set the item [31] to "2P1," all of the P1/P2 inverter item [68] can not be set, it is default "0" and the phase difference between P1 and P2 is 120°. When setting the item [38] to "120 V," the voltage between the live wire L1 of P1 phase and the live wire L2 of P2 phase is 208 V, and the L1-N voltage is 120 V
- (2) P1: Set the item [31] to "2P0;" P2: Set the item [31] to "2P2," all of the P1/P2 inverter item [68] can not be set, it is default "0" and the phase difference between P1 and P2 is 180°. When setting the item [38] to "120 V," the voltage between the live wire L1 of P1 phase and the live wire L2 of P2 phase is 240 V, and the L1-N voltage is 120 V, L2-N voltage is 120V

a. Split-phase system (two inverters)

1+1 system:

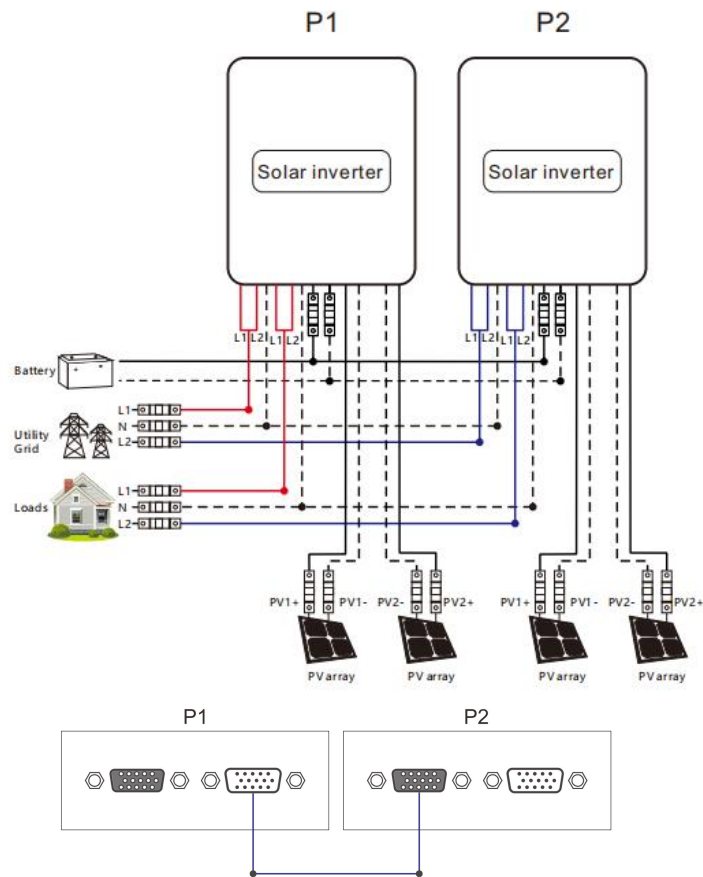

b. Split-phase system (three inverters)

2+1 system

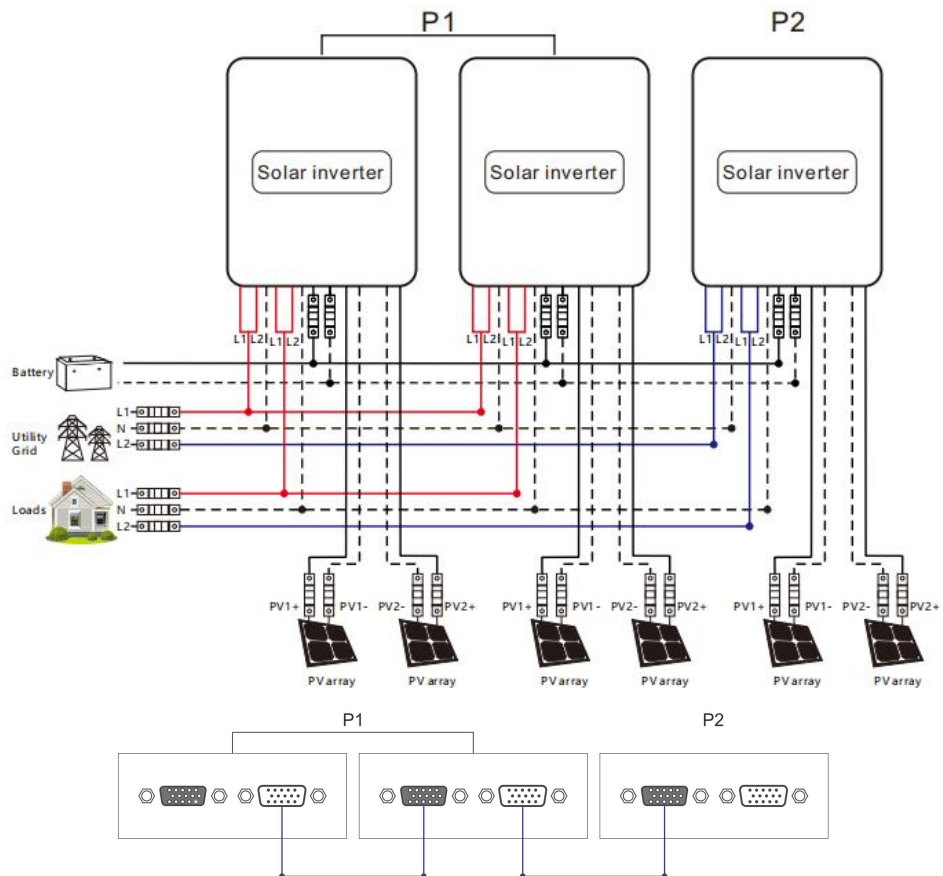

c. Split-phase system (four inverters)

3+1 system:

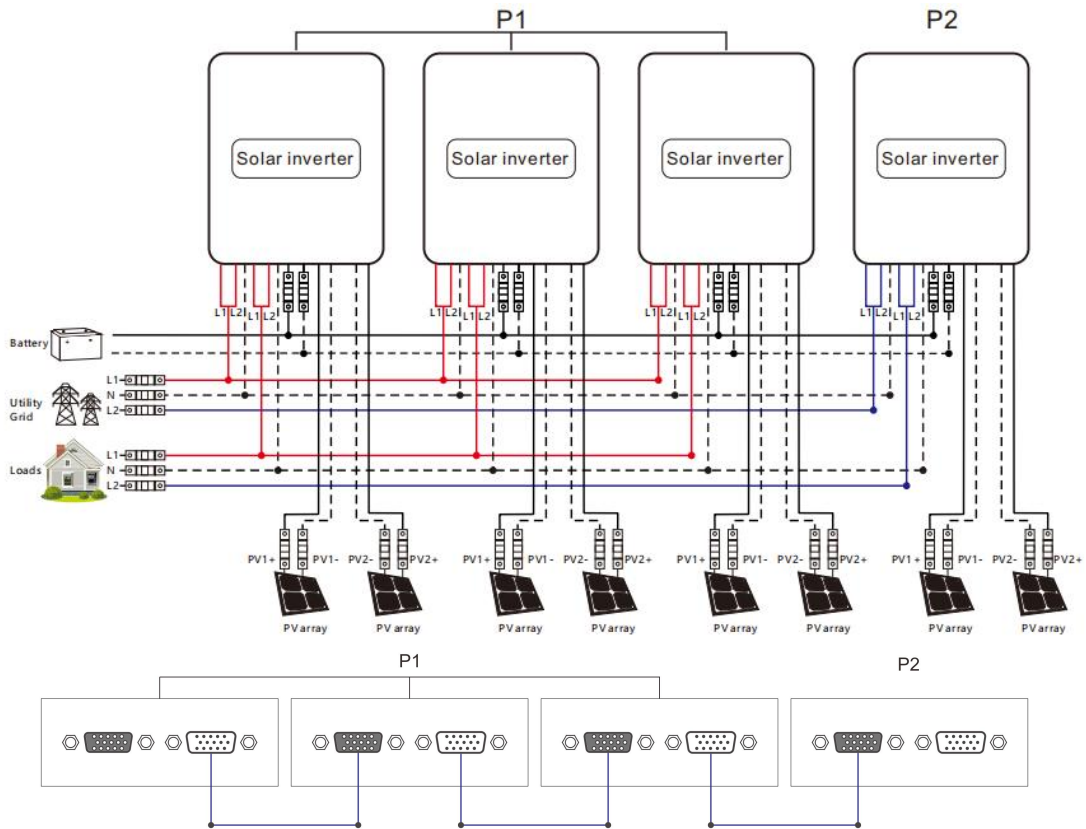

2+2 system:

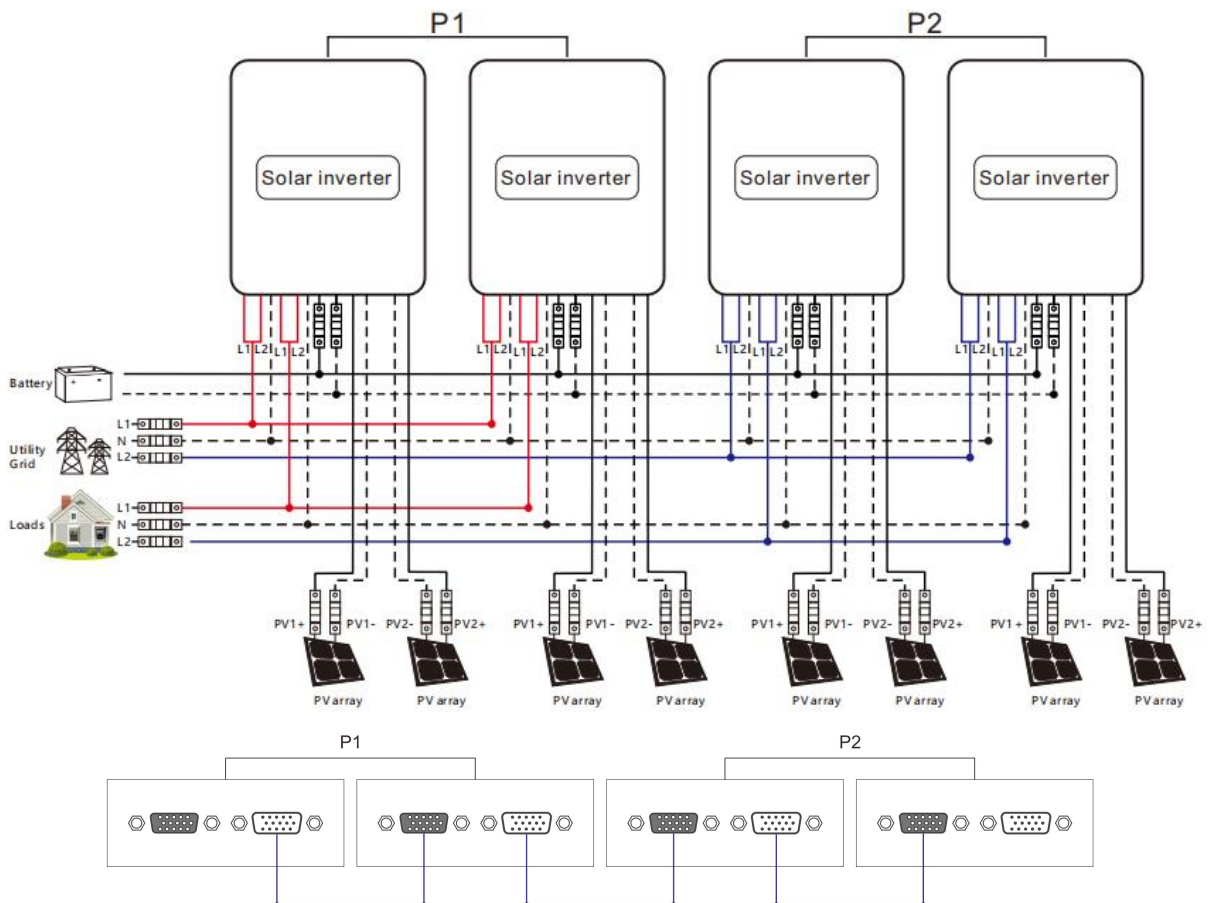

d. Split-phase system (five inverters)

4+1 system:

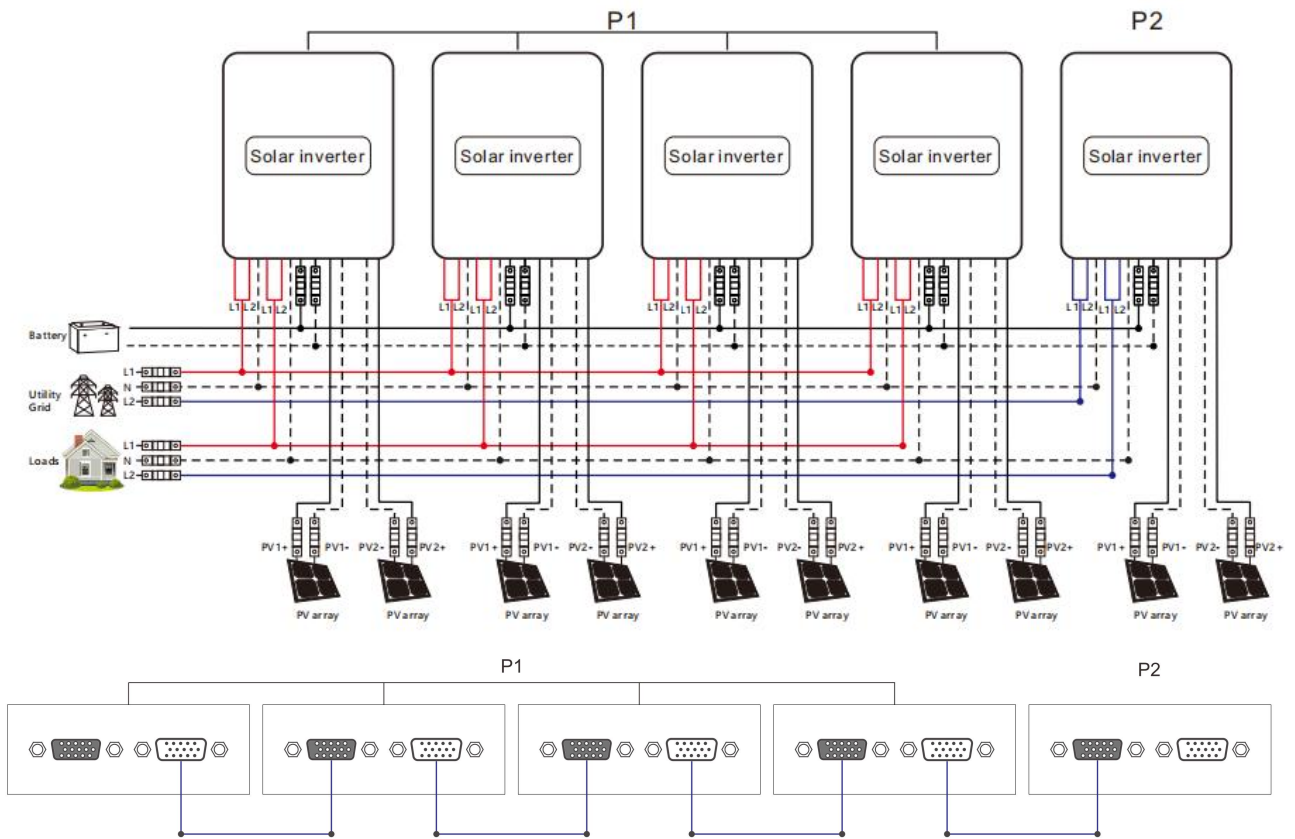

3+2 system:

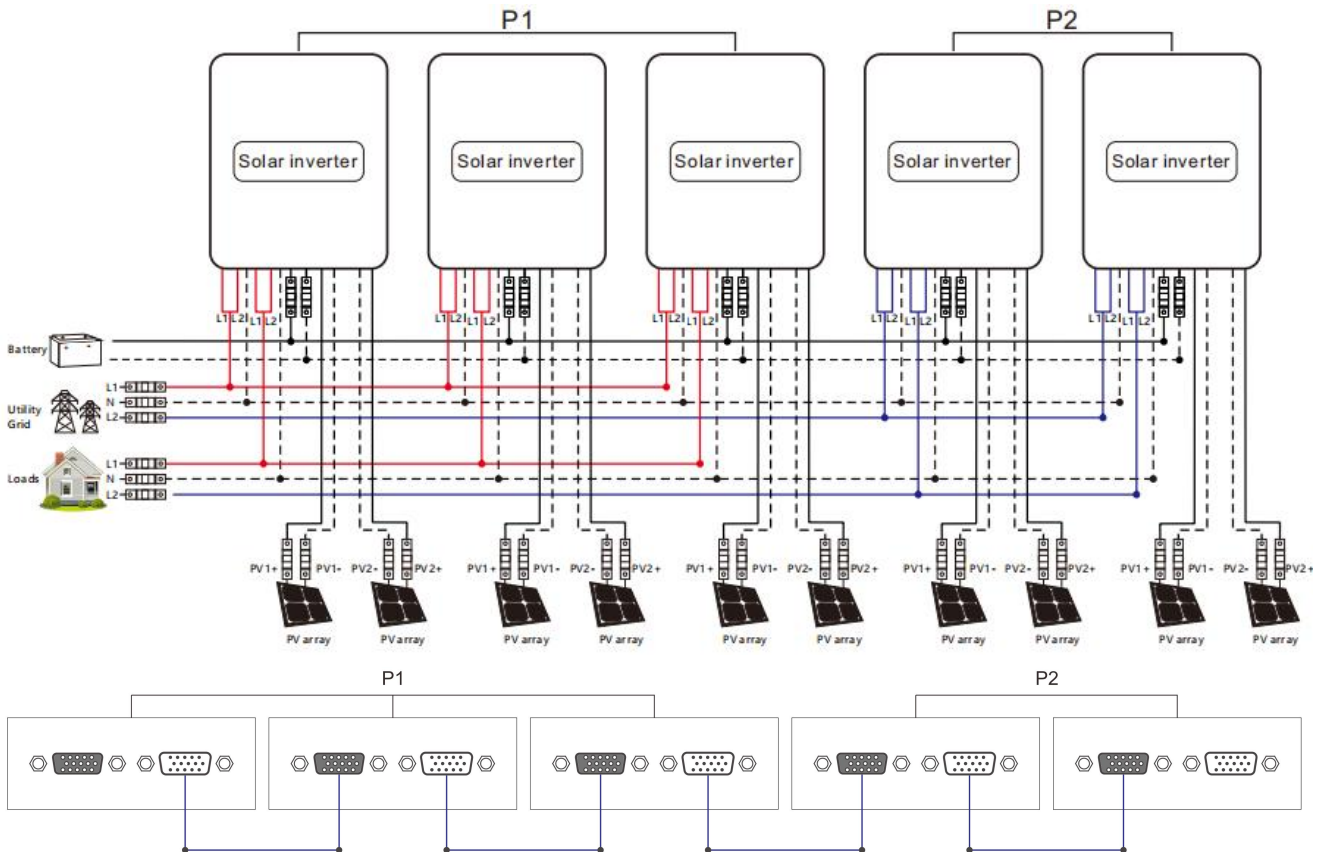

3+3 system:

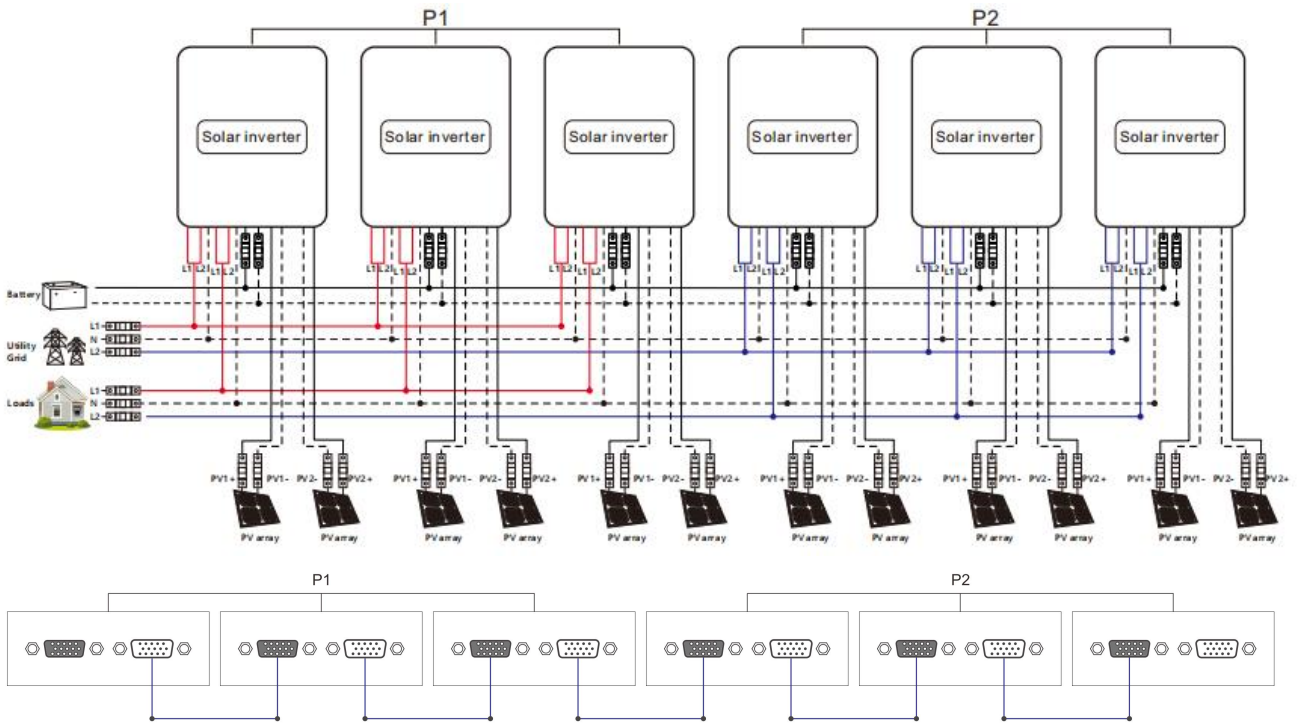

4.9.5 Wiring diagram for split-phase parallel connection (phase difference between L1 and L2: 180°)

Set the item [31] to PAL, and set the item [68] to 180°. When setting the item [38] to "120 V," the L1-L2 voltage is 240 V, and the L1-N voltage is 120 V, L2-N voltage is 120V

a. Two parallel-connected solar storage inverters:

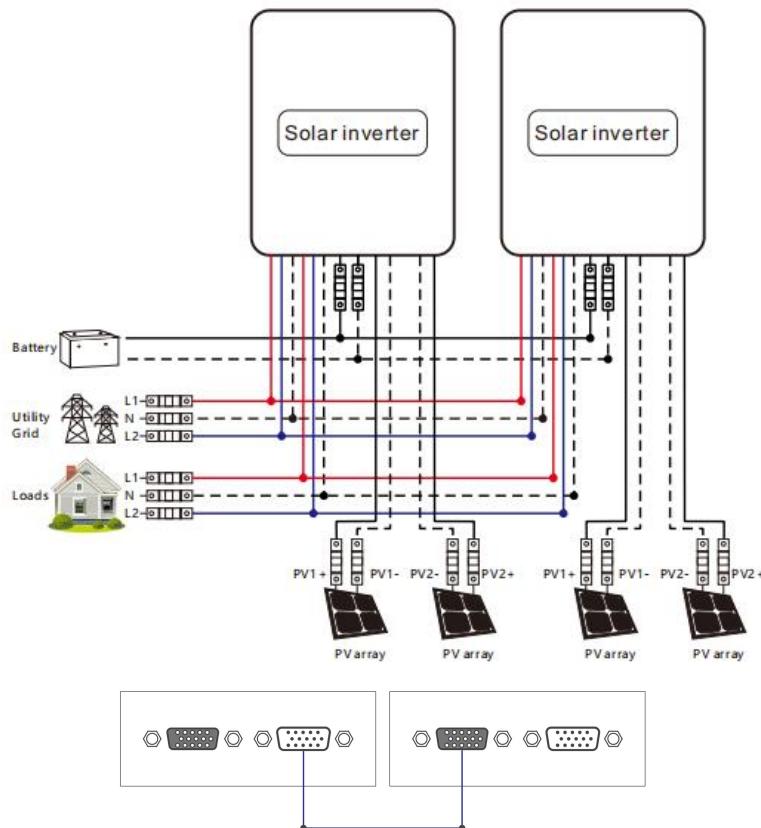

b. Three parallel-connected solar storage inverters:

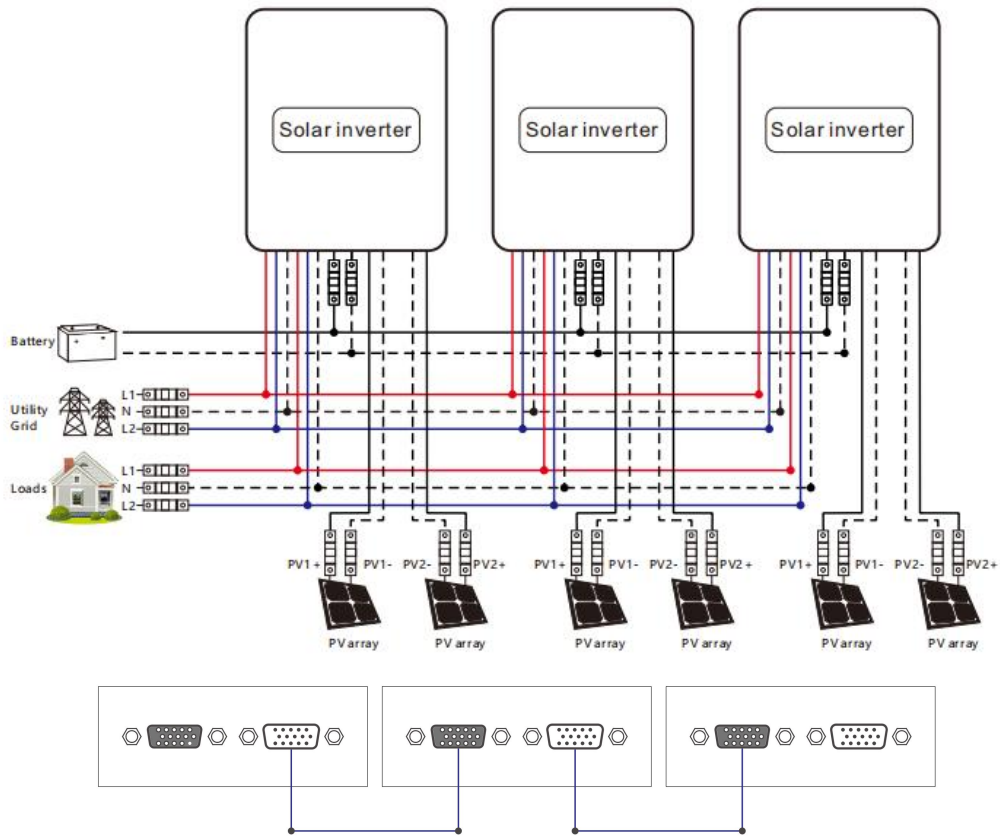

c. Four parallel-connected solar storage inverters:

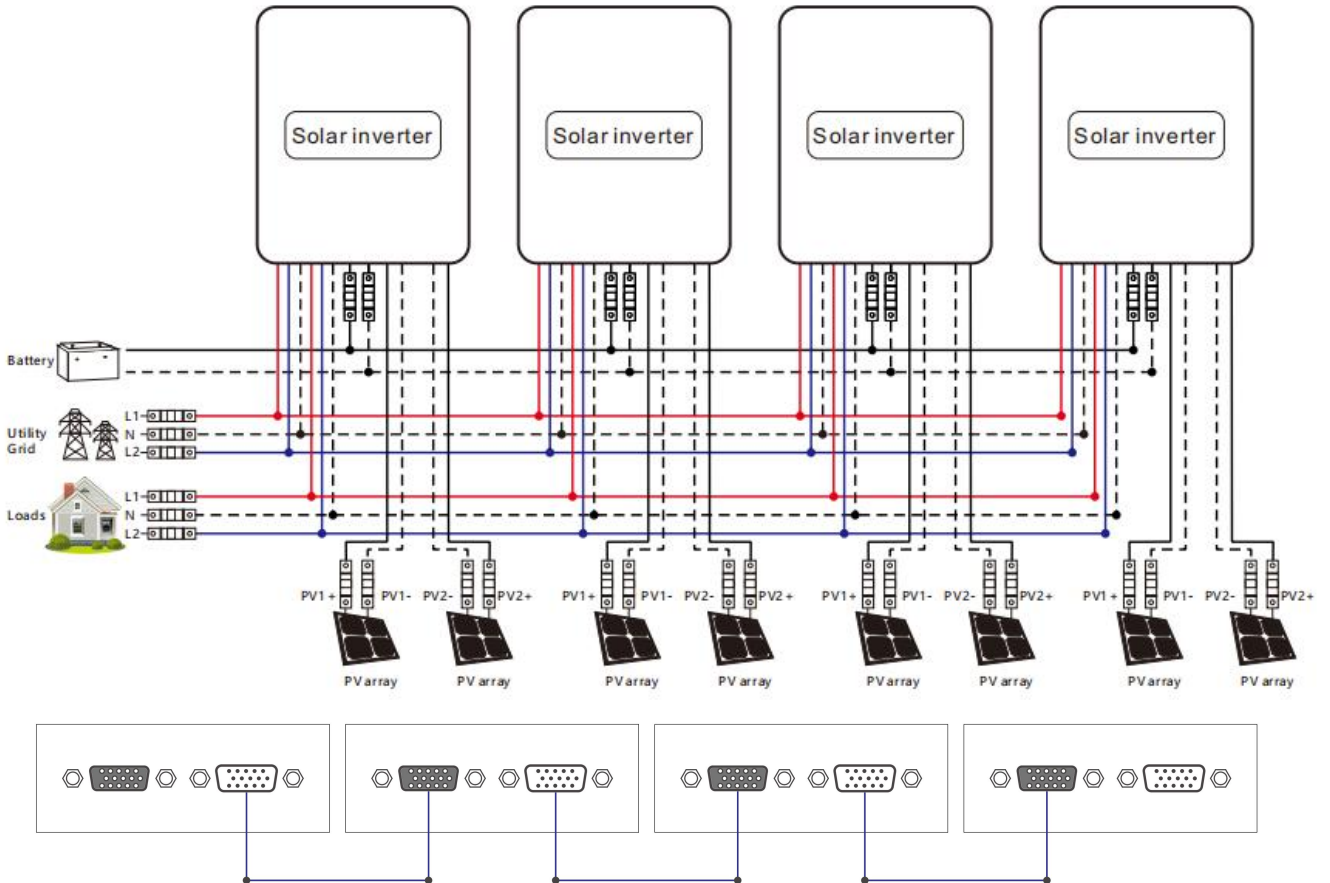

d. Five parallel-connected solar storage inverters:

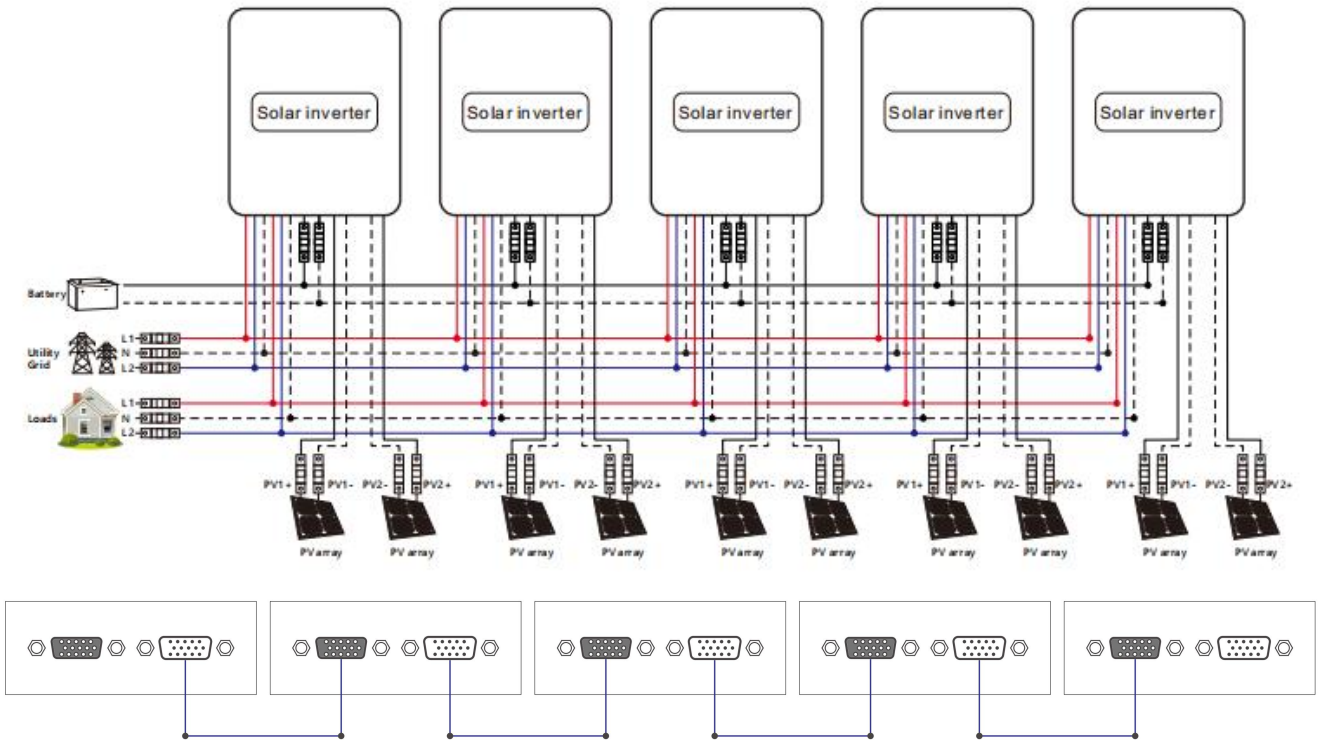

e. Six parallel-connected solar storage inverters:

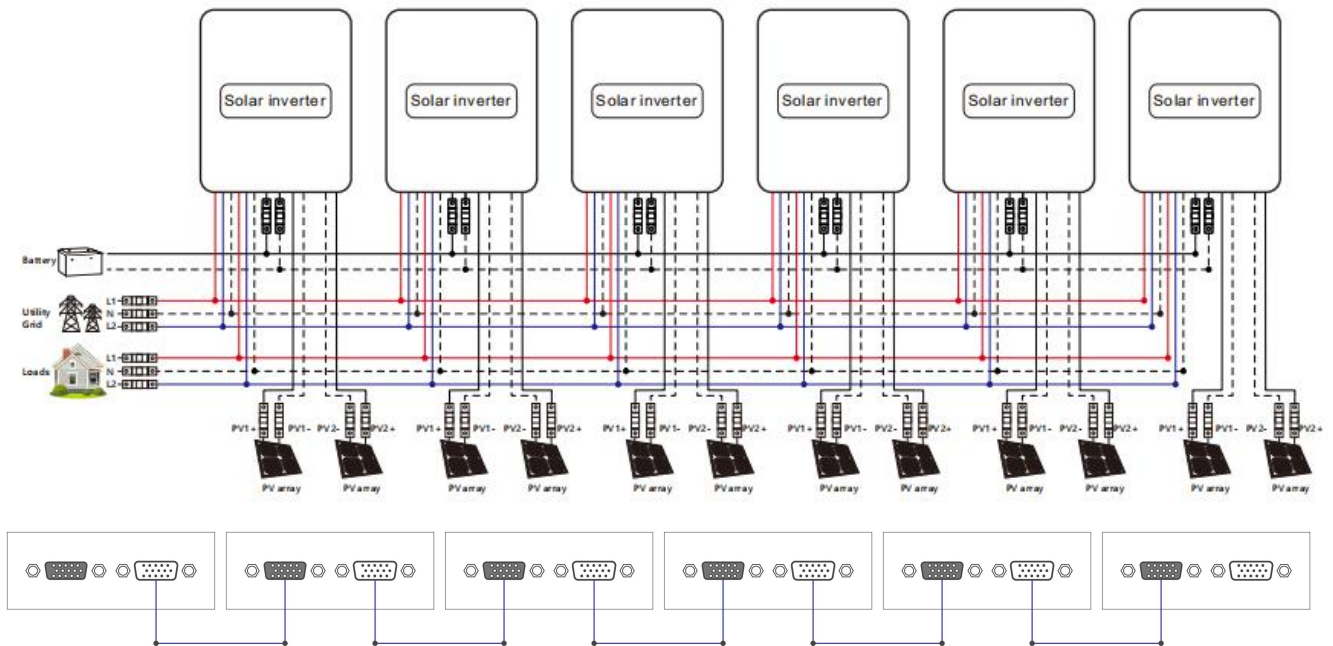

4.9.6 Wiring diagram for three-phase parallel connection

P1: Set the item [31] to "3P1;" P2: Set the item [31] to "3P2;" P3: Set the same to "3P3" , all of P1/P2/P3 inverters item [68] can not be set, it is default "0°"

At this point, the P1-P2, P1-P3, and P2-P3 phase difference is 120°. When setting the item [38] to "120 VAC," the voltage between the live wire L1 of P1 phase and the live wire L2 of P2 phase is $230 \times 1.732 = 208$ VAC. Similarly, the L1-L3 and L2-L3 voltage is 208 VAC:

a. Three-phase system (three inverters)

1+1+1 system:

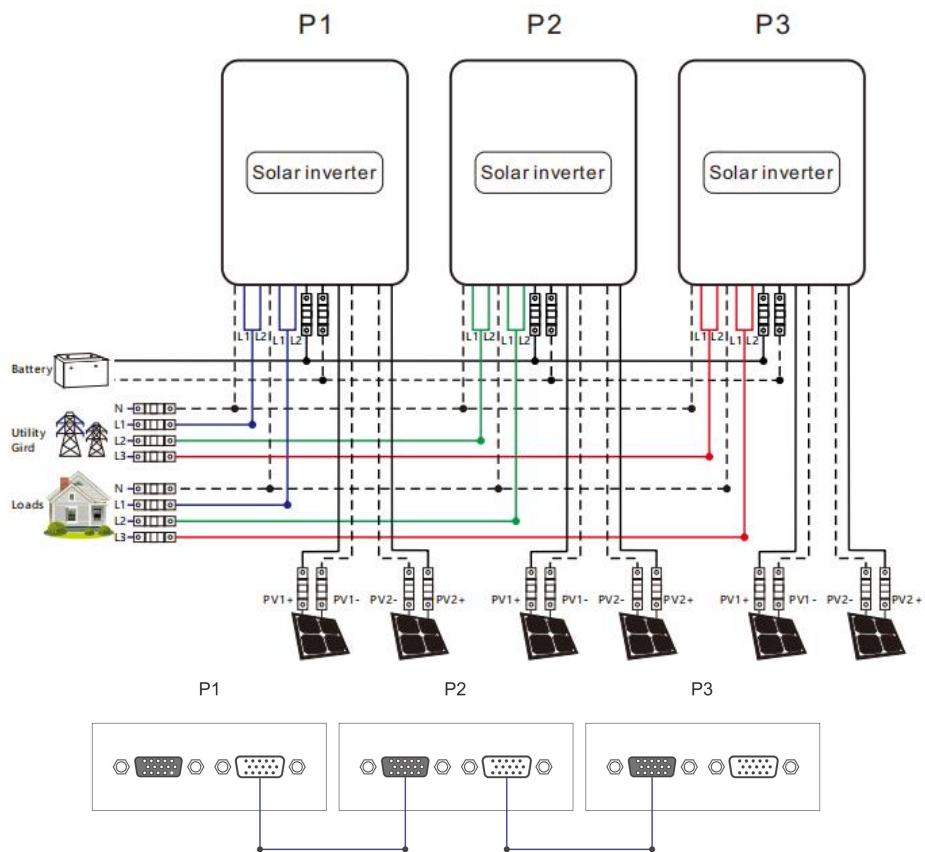

b. Three-phase system (four inverters)

2+1+1 system:

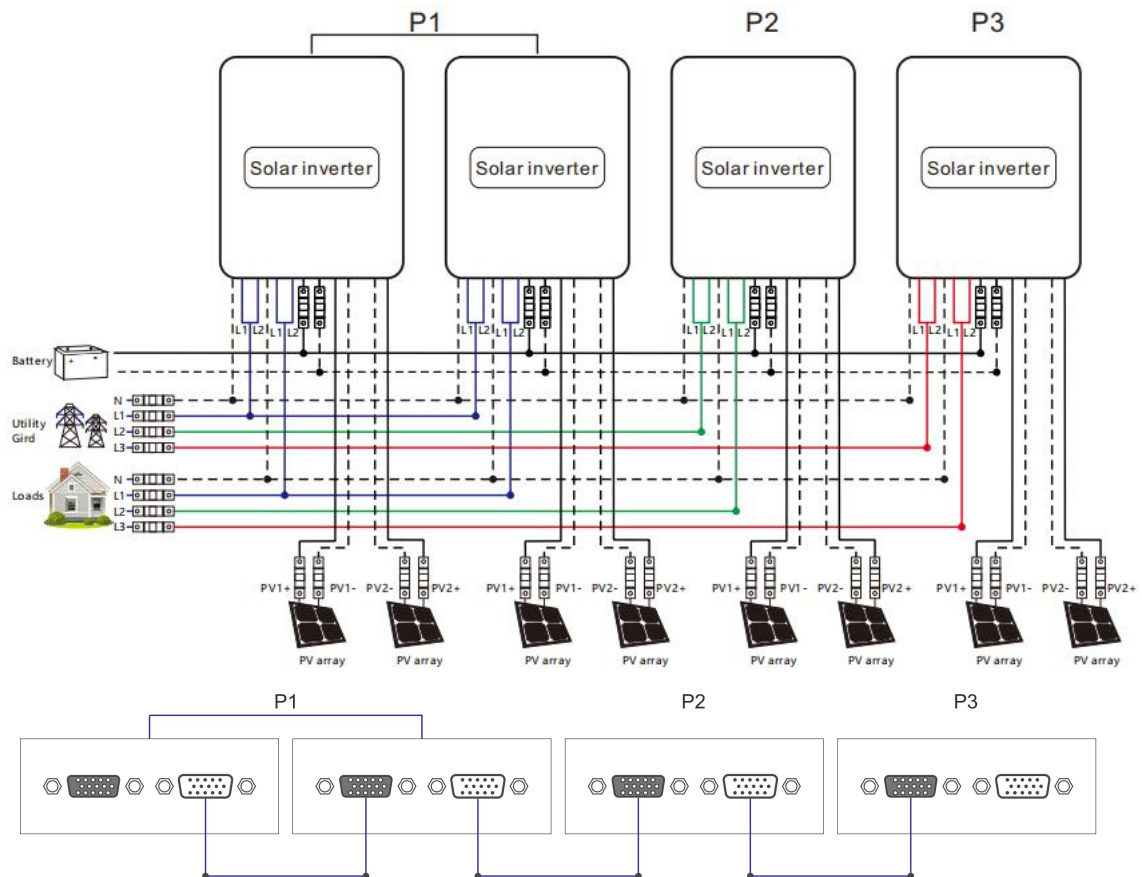

c. Three-phase system (five inverters)

3+1+1 system:

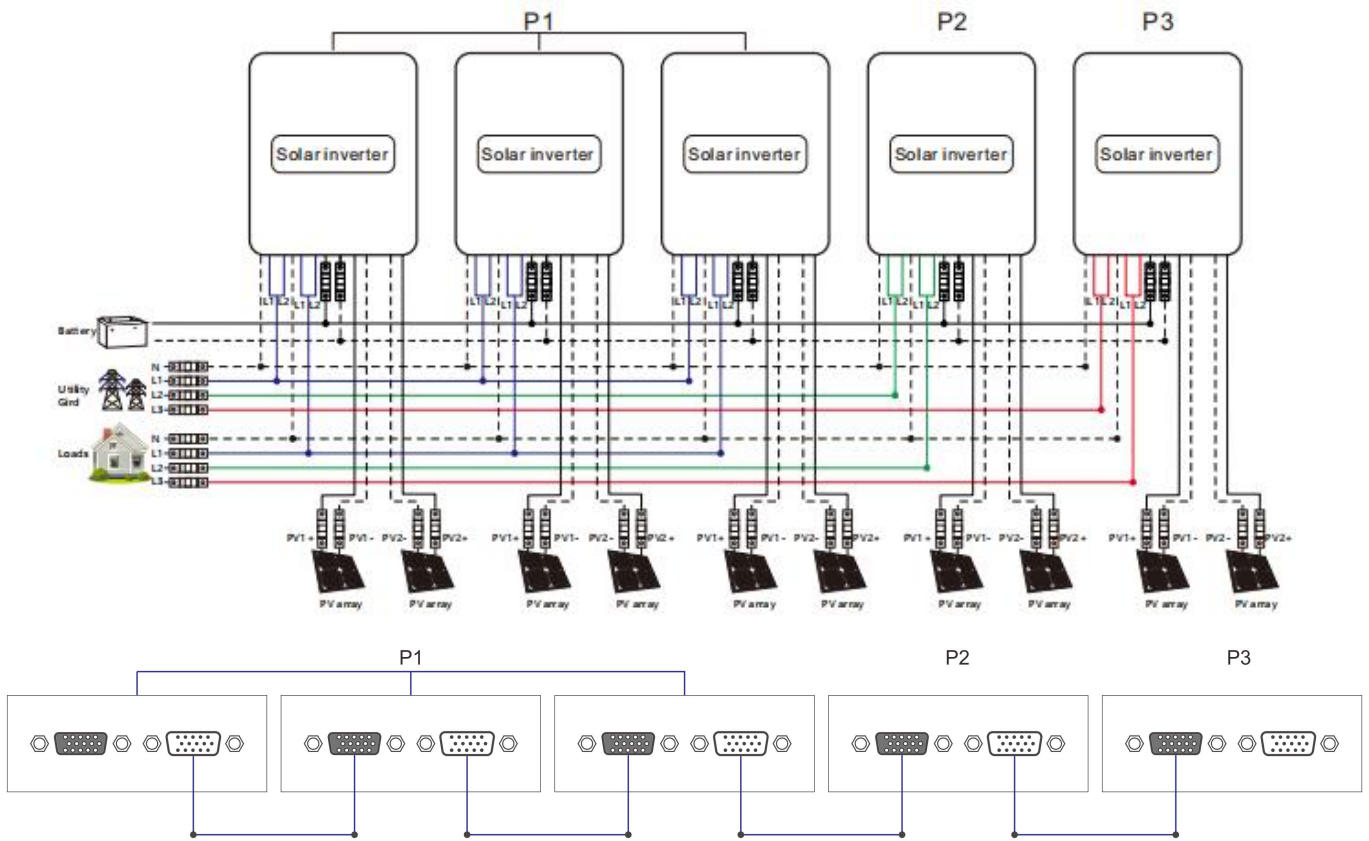

2+2+1 system:

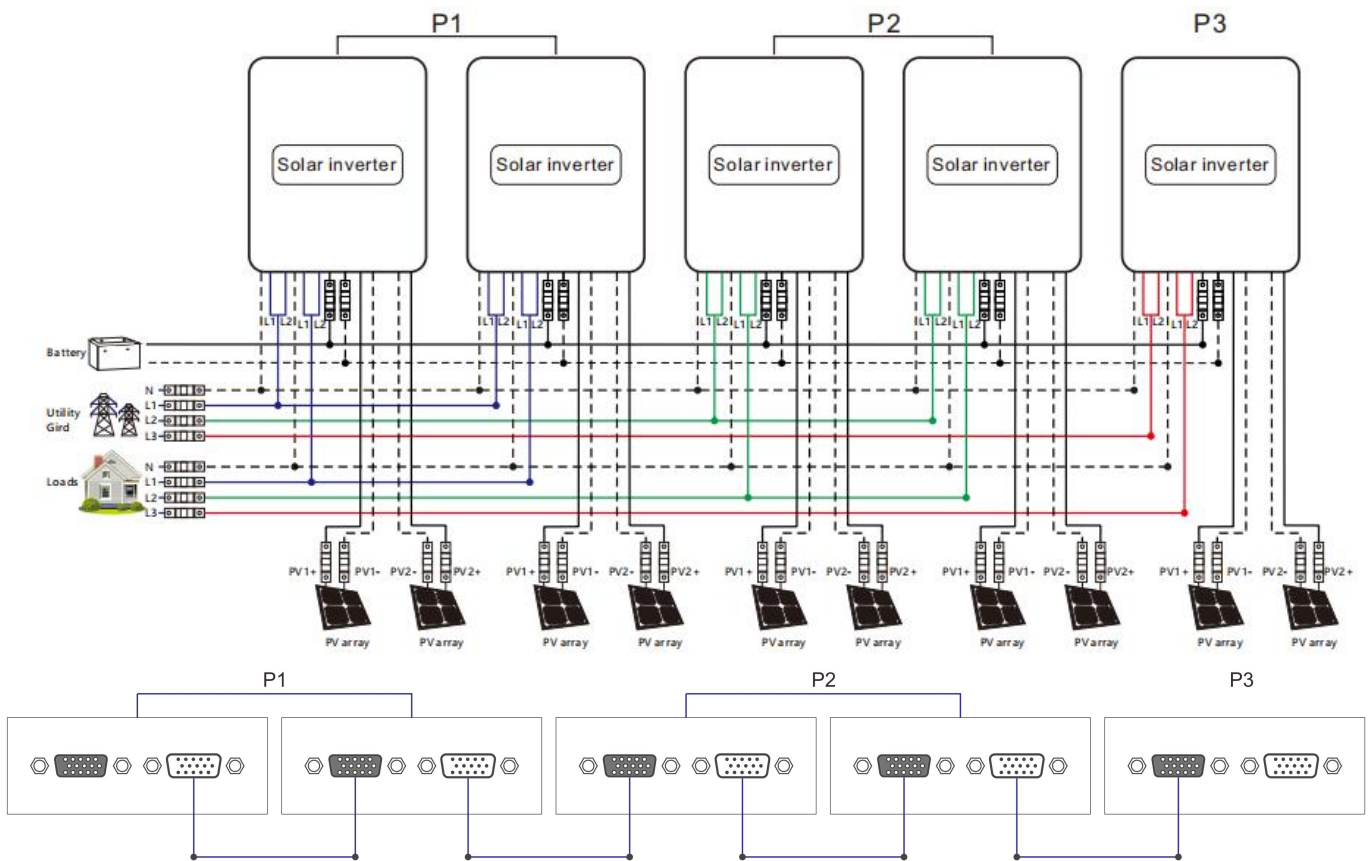

d. Three-phase system (six inverters)

2+2+2 system:

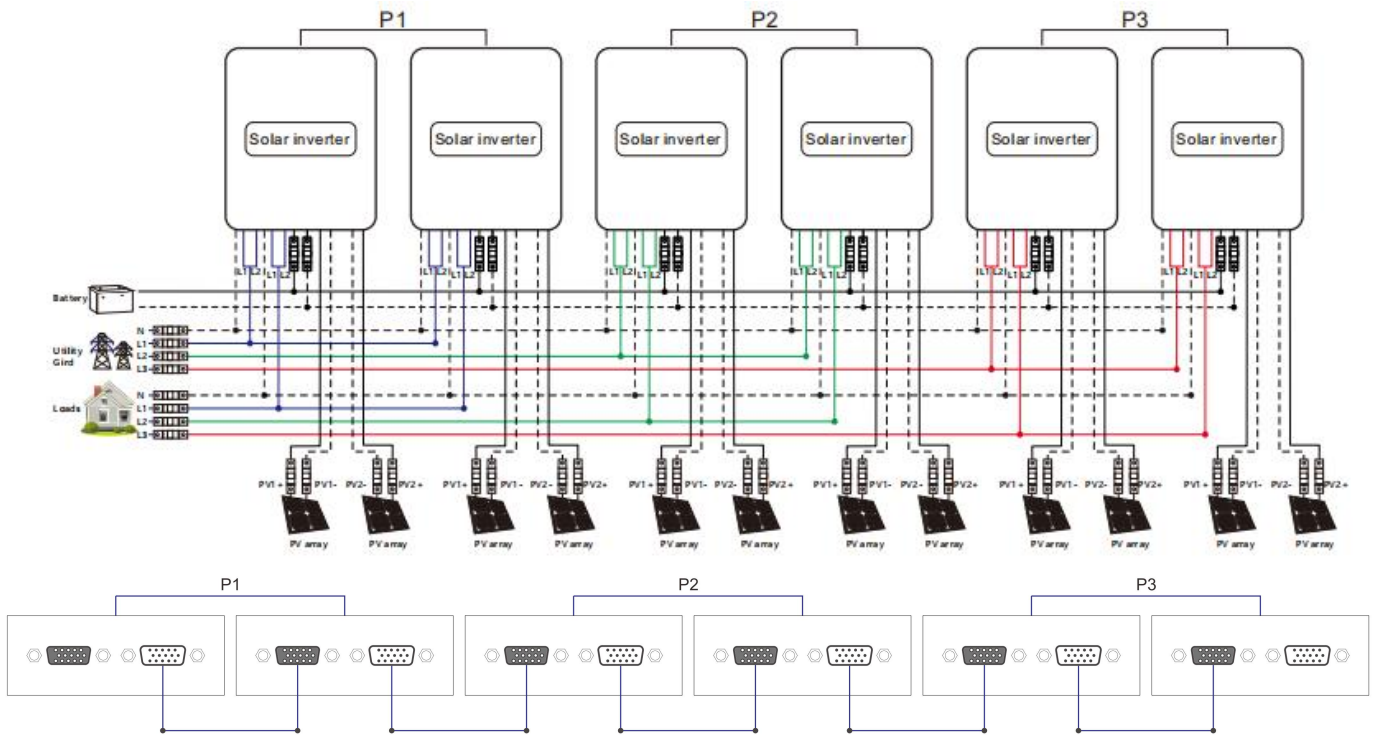

3+2+1 system:

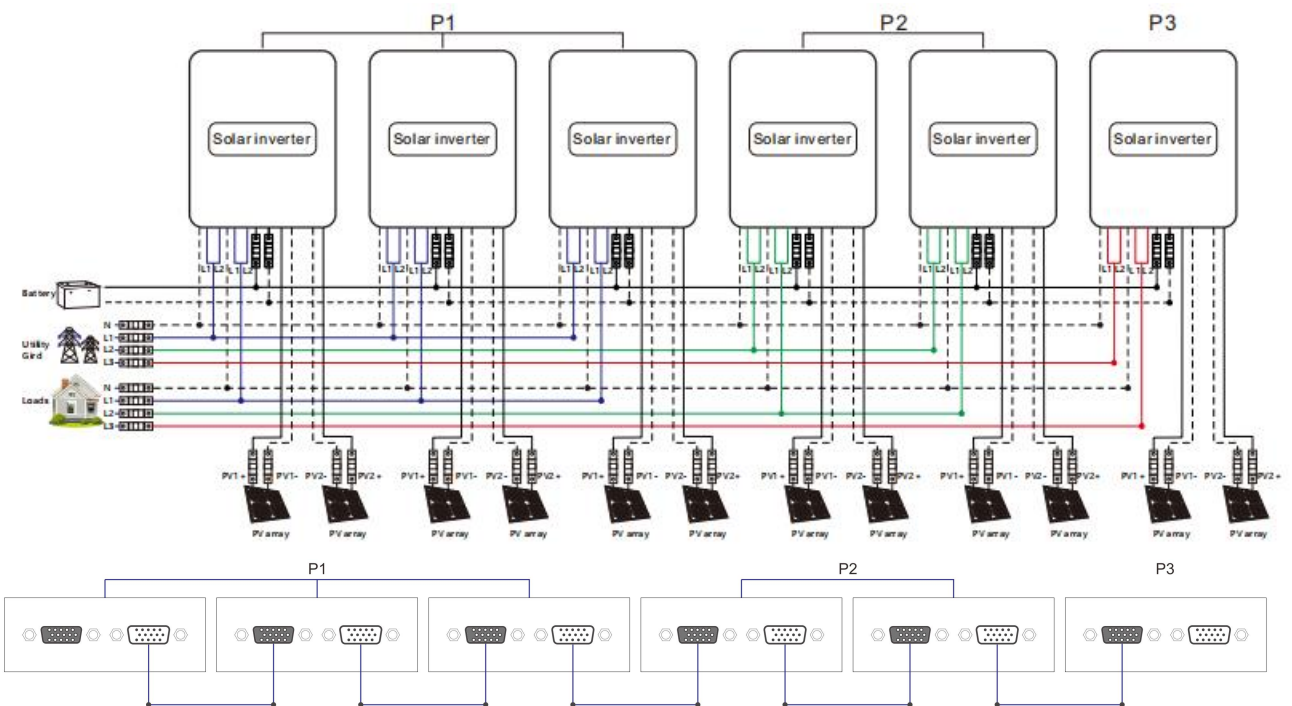

Note:

1) Before powering on and lighting up the screen, check for correct wiring according to the above wiring diagrams to avoid system problems.

2) Check all connections for firm fixing to avoid detachment and abnormal system operation.

3) When connecting the AC output to the load, complete wiring according to the requirements of the electrical load to avoid damage to the load.

3) Set the item [38] to the same parameter, or only set it in the host inverter. During parallel operation, the voltage set in the host shall prevail, so the host inverter will forcibly set the item to the value for slave inverters. Only in standby mode can the item be set.

5) The inverter defaults to single mode at the factory. If using the parallel or three-phase function, set the item [31] on the screen as follows:

Power on one inverter each time, turn off the other inverters, and then set the item [31] according to the on-site system operation mode. After setting the inverter, turn off the inverter, and set the other inverters one by one. After all are set, power on all inverters at one time to enter the working state.

In single-phase parallel operation:

Set the item [31] to "PAL" and the item [68] to "0°." When setting the item [38] to "120 V," the output L-N voltage is 120 V

In two-phase parallel operation:

(1) P1: Set the item [31] to "2P0;" P2: Set the item [31] to "2P1," all of P1/P2 inverters item [68] can not be set, it is default "0°" and the phase difference between P1 and P2 is 120°. When setting the item [38] to "120 V," the voltage between the live wire L1 of P1 phase and the live wire L2 of P2 phase is 208 V, and the L1-N voltage is 120 V

(2) P1: Set the item [31] to "2P0;" P2: Set the item [31] to "2P2," all of P1/P2 inverters item [68] can not be set, it is default "0°" and the phase difference between P1 and P2 is 180°. When setting the item [38] to "120 V," the voltage between the live wire L1 of P1 phase and the live wire L2 of P2 phase is 240 V, and the L1-N voltage is 120 V

In split-phase parallel operation:

Set the item [31] to PAL, and set the item [68] to 180°. When setting the item [38] to "120 V," the L1-L2 voltage is 240 V, and the L1-N voltage is 120 V

In three-phase parallel operation:

P1: Set the item [31] to "3P1;" P2: Set the item [31] to "3P2;" P3: Set the same to "3P3" all of P1/P2/P3 inverters item [68] can not be set, it is default "0°"

At this point, the P1-P2, P1-P3, and P2-P3 phase difference is 120°. When setting the item [38] to "120 VAC," the voltage between the live wire L1 of P1 phase and the live wire L2 of P2 phase is $120 \times 1.732 = 208$ VAC. Similarly, the L1-L3 and L2-L3 voltage is 208 VAC:

6) After the system runs, measure the correct output voltage before connecting to loads.

5. Operation

5.1 Operation and display panel

The operation and display panel of the inverter includes one LCD screen, three indicators, and four physical buttons

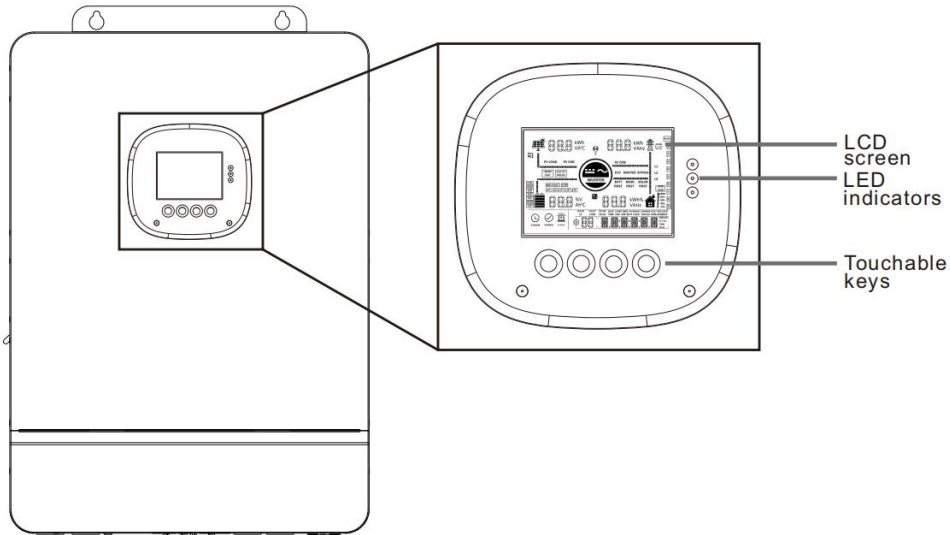

- **Physical button**

Physical button	Description
	Enter/Exit the setup menu
	Go to the next option
	Go to the previous option
	Confirm/Enter the option in setup menu

- **LED indicator**

Indicator	Color	Description
AC/INV	Yellow	Normally ON: mains bypass output
		Flash: inverter output
CHARGE	Green	Normally ON: charging completed
		Flash: charging
FAULT	Red	Normally ON: level-1 fault
		Flash: level-2 fault
		OFF: level-3 or level-4 fault

- **Display screen**

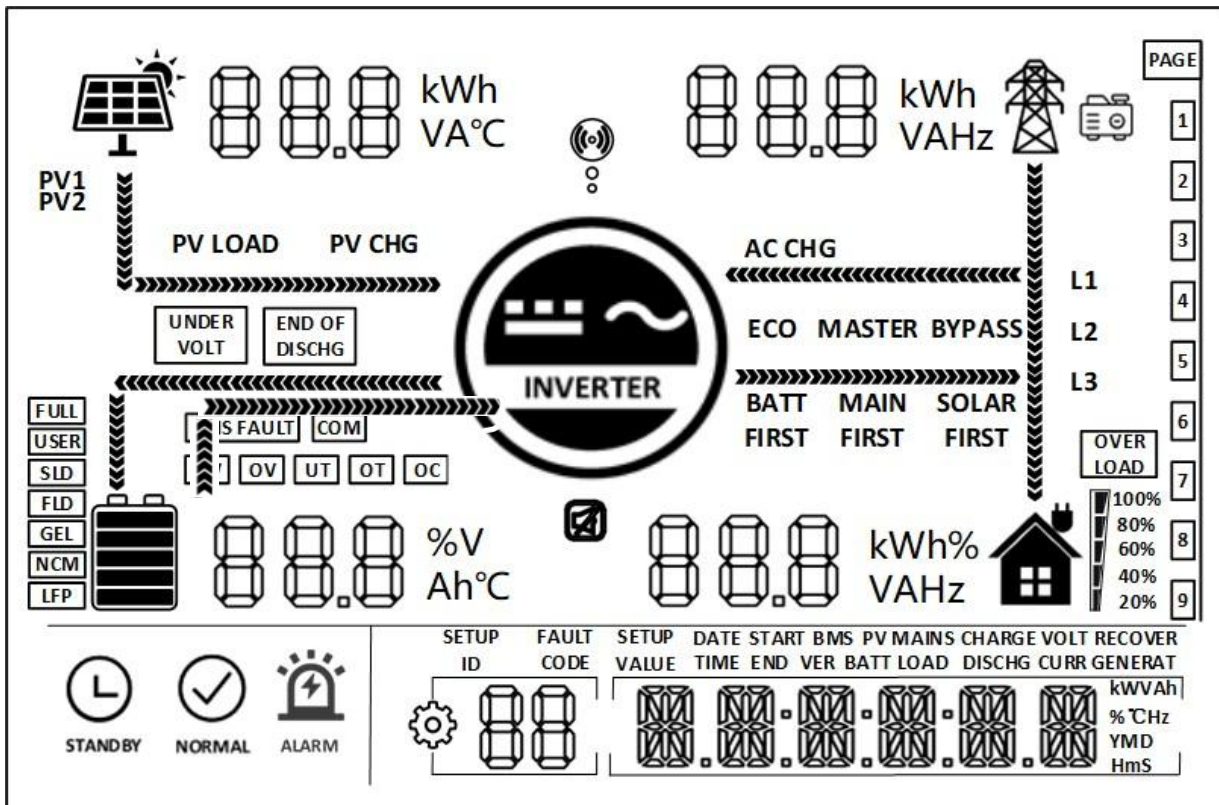

Icon	Description	Icon	Description
	PV panel		Mains
	Battery		Generator
	The inverter is working		Load
	The inverter is communicating with the data collector		The buzzer is in mute mode
	Power flow direction		
	The inverter is in standby mode		The inverter is working normally
	There is a fault		Settings
	Load power: 80%–100%		SOC: 80%–100%
	Load power: 60%–79%		SOC: 60%–79%
	Load power: 40%–59%		SOC: 40%–59%
	Load power: 20%–39%		SOC: 20%–39%
	Load power: 5%–19%		SOC: 5%–19%

Icon	Description	Icon	Description
UNDER VOLT	Battery under-voltage	END OF DISCHG	Battery over-discharge
OVER LOAD	Overload	BMS FAULT	BMS fault
COM	System communication error	UV	System under-voltage
OV	System overvoltage	UT	Too low system temperature
OT	Too high system temperature	OC	System overcurrent
FULL	Battery full power	USER	User-defined battery
SLD	Sealed lead-acid battery	FLD	Flooded lead-acid battery
GEL	Gel lead-acid battery	NCM	Ternary Li-ion battery
LFP	LFP Li-ion battery	ECO	Energy-saving mode
PVLOAD	PV power is loading	PVCHG	PV power is charging the battery
ACCHG	AC input power is charging the battery	MAINS FIRST	The output mode of the inverter is mains first
BYPASS	The output mode of the inverter is mains bypass	SOLAR FIRST	The output mode of the inverter is PV first
BATT FIRST	The output mode of the inverter is battery first		

- **Real-time parameters view**

On the screen, press the UP/DOWN button to view real-time data of the inverter in operation

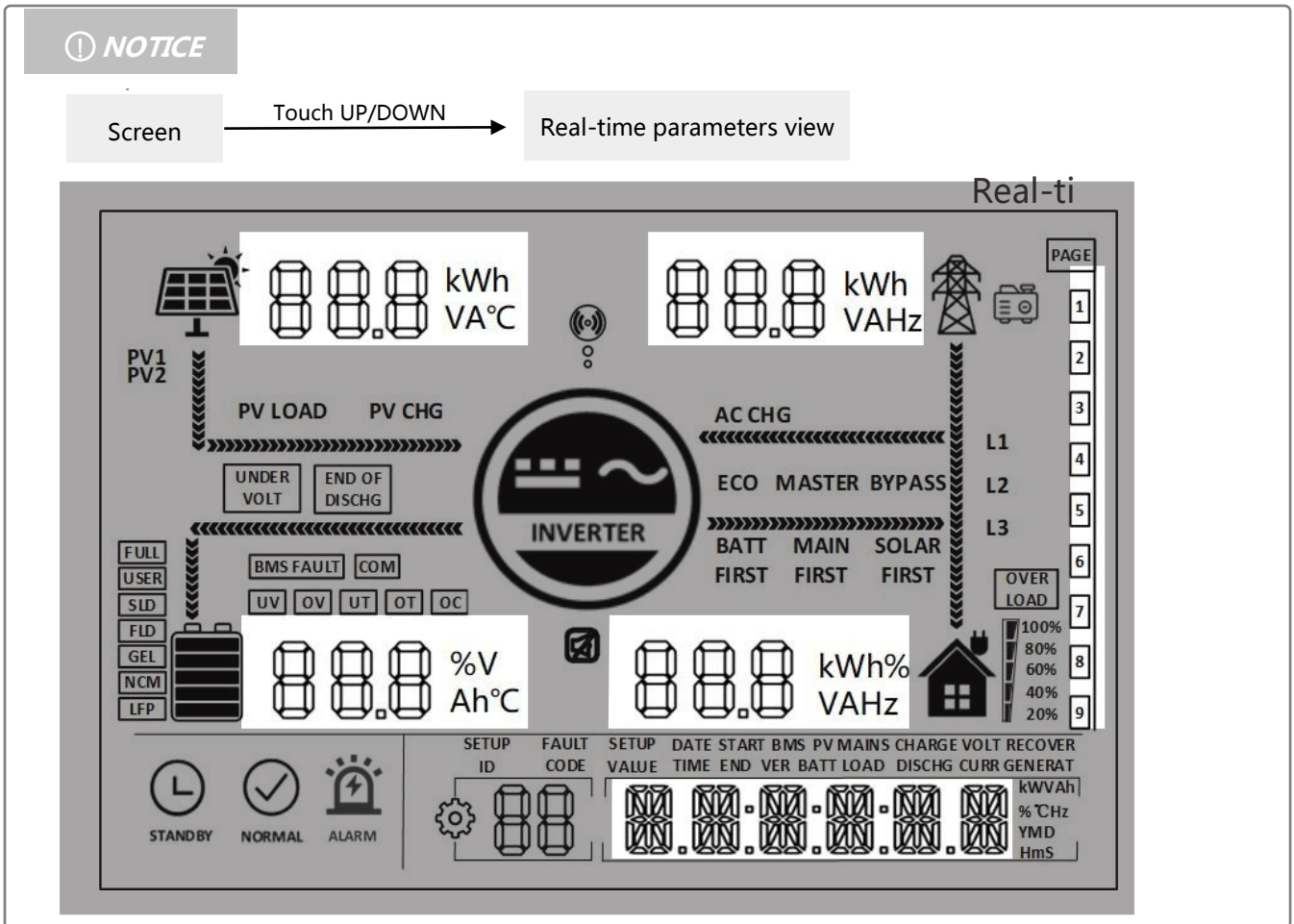

Page	PV	Battery	AC input	Load	General
1	PV input voltage	Battery voltage	Mains input voltage	Single-phase voltage	Current time
2	PV input current	Battery current	Mains input current	Single-phase current	Current date
3	PV input power	BMS Battery voltage	Mains total input power	Single-phase active power	PV gross generation
4	PV generation for the day	Battery SOC	Mains charging capacity for the day	Single-phase apparent power	Total load consumption
5	PV heat sink temperature	Heat sink temperature	Mains frequency	Inverter output frequency	RS485 address
6	Rated open circuit voltage	Rated battery voltage	Bus voltage	Rated output frequency	Software version
7	Maximum PV charge current	Maximum battery charge current	Maximum mains charge current	Total output active power	/
8			/	Total output apparent frequency	/

5.2 Setting

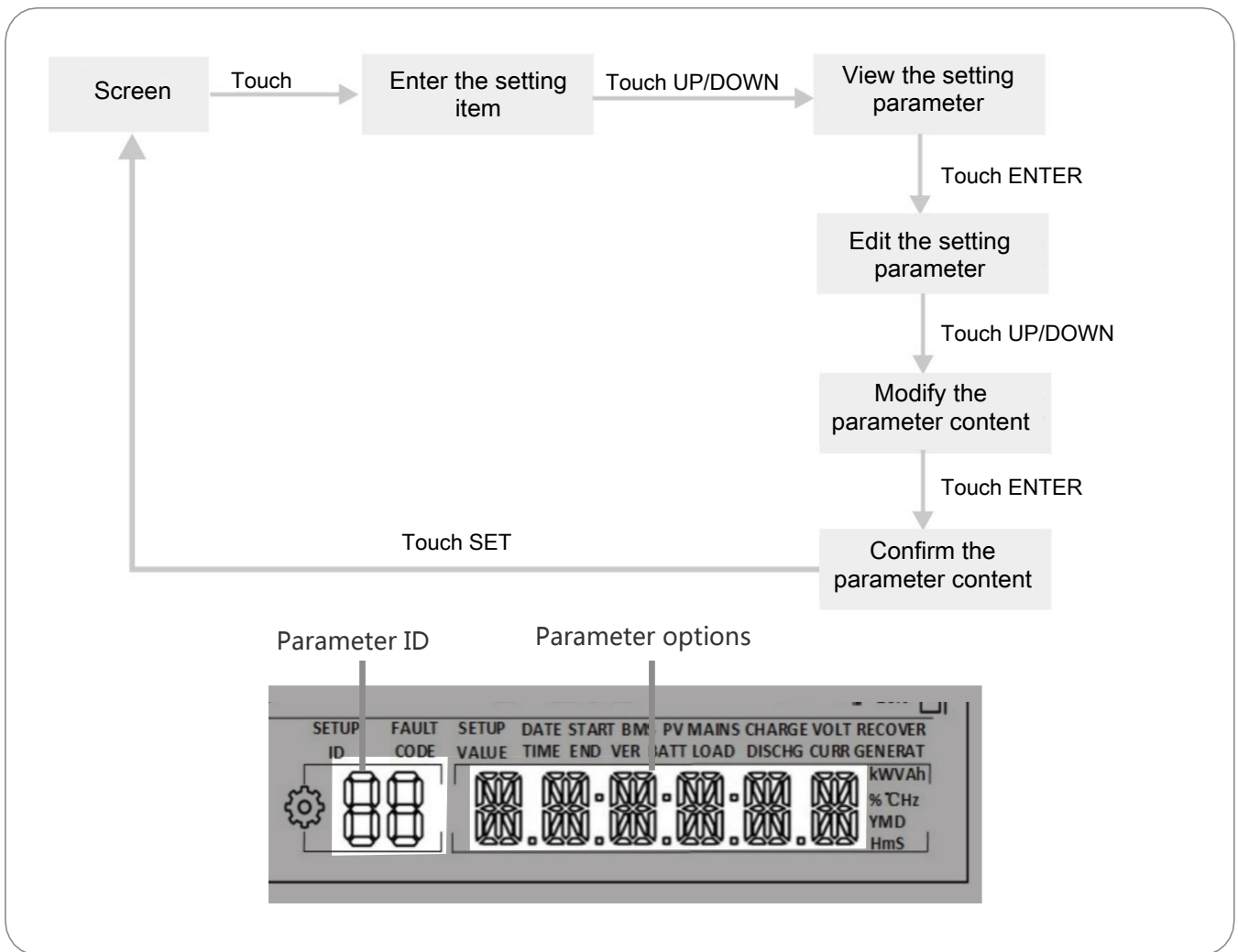

ID	Parameter	Option	Description
The voltage setting logic: 【15】 < 【12】 < 【04】 < 【14】 < 【35】 < 【37】 < 【05】 < 【09/11】			
00	Exit	ESC	Exit the setup menu
01	AC output mode	UTI	Photovoltaic energy priority with the load, photovoltaic is not enough, the grid power and photovoltaic mixed load, photovoltaic energy is enough with the load, the excess energy to charge the battery, the grid power only starts charging when the battery is too discharged (06 Settings as "OSO(only PV)"), the grid power will not charge), the battery is only discharged when off the grid
		SBU	Inverter first. The PV mode is to be applied first for loading, and only when the battery voltage is lower than the set value in the item 4, it will switch to the mains mode for loading. When the battery voltage is higher than the set value in the item 5, it will switch back to the PV mode from the mains mode.

ID	Parameter	Option	Description
		SOL	The PV mode is to be applied first and when the PV power is unavailable or the battery voltage is lower than the set value in the item 4, it will switch to the mains mode
		SUB(default)	Solar energy priority charging, insufficient solar energy, grid energy and solar energy hybrid charging (if 06 Settings as "OSO(only PV) ", the grid energy will not charge) and grid with load, when solar energy is enough to charge, excess energy not enough to load, excess solar energy and grid will hybrid load, the battery is discharged only when off the grid
02	AC input frequency	50.0	In bypass mode, the AC output frequency will adapt to the mains frequency, and in other cases, the output will follow the preset value.
		60.0 (default)	
03	AC input voltage range	UPS (default)	When the output voltage is 120/110 V, the input voltage range is 90 V–140 V
		APL	When the output voltage is 100/105 V, the input voltage range is 85 V–140 V
04	Battery to mains voltage threshold	43.6 (default)	When the parameter item 01 is SBU or SOL and the battery voltage is lower than the threshold, the output switches from inverter to mains. Setting range: 40 V–52 V
05	Mains to battery voltage threshold	57.6 (default)	When the parameter item 01 is SBU or SOL and the battery voltage is higher than the threshold, the output switches from mains to inverter. Setting range: 48 V–60 V
06	Battery charge mode	SNU (default)	When both PV power and mains are used to charge the battery at one time, the PV charge first and when the PV power is insufficient, the mains tags in. Only in bypass mode can both PV power and mains be used to charge the battery at one time, and only the PV charge mode can be enabled during inverter operation.
		OSO	Do not enable the mains charge mode when in only PV charge mode
07	Battery charge current	60	SPI-8K-UP, setting range: 0 A–180 A
			SPI-10K-UP, setting range: 0 A–200 A
08	Battery type	USER	User-defined, and in this type, you can set all battery parameters
		SLD	Sealed lead-acid battery
		FLD	Flooded lead-acid battery
		GEL (default)	Gel lead-acid battery
		L14/L15/L16	LFP battery L14/L15/L16, corresponding to 14, 15, and 16 series of LFP batteries
		N13/N14	Ternary Li-ion battery N13/N14, corresponding to 13 and 14 series of ternary Li-ion batteries

ID	Parameter	Option	Description
		NOb	No battery
09	Battery boost charge voltage	57.6	Setting range: 48 V–58.4 V, with a step of 0.4 V, available for user-defined and lithium-ion battery types
10	Boost charge duration	120	The continuous charging time when the voltage reaches the set voltage during constant voltage charging, with a setting range of 5 min–900 min and a step of 5 min
11	Battery floating charge voltage	55.2	Setting range: 48 V–58.4 V, with a step of 0.4 V. This parameter cannot be set after successful BMS communication
12	Battery over-discharge voltage (delayed shutdown)	42	When the battery voltage is lower than the voltage and triggers the set value in the item 13, it will turn off the inverter output. Setting range: 40 V–48 V, with a step of 0.4 V
13	Battery over-discharge delay time	5	When the battery voltage is lower than the set value in the item 12 and triggers the delay time set in this parameter item, it will turn off the inverter output. Setting range: 5s–50s, with a step of 5s
14	Battery under-voltage alarm threshold	44	When the battery voltage is lower than the threshold, it will give an under-voltage alarm and the output will not shut down. Setting range: 40 V–52 V, with a step of 0.4 V
15	Battery discharge limit voltage	40	When the battery voltage is lower than the value, the output immediately shuts down. Setting range: 40 V–52 V, with a step of 0.4 V, available for user-defined and Li-ion batteries
16	Battery equalizing charge	DIS	Disable equalizing charge
		ENA (default)	Enable equalizing charge, but only available for flooded lead-acid batteries, sealed lead-acid batteries, and user-defined ones
17	Equalizing charge voltage	58	Setting range: 48 V–58 V, with a step of 0.4 V, but only available for flooded lead-acid batteries, sealed lead-acid batteries, and user-defined ones
18	Equalizing charge duration	120	Setting range: 5 min–900 min, with a step of 5 min, but only available for flooded lead-acid batteries, sealed lead-acid batteries, and user-defined ones
19	Equalizing charge delay time	120	Setting range: 5 min–900 min, with a step of 5 min, but only available for flooded lead-acid batteries, sealed lead-acid batteries, and user-defined ones
20	Equalizing charge interval	30	Setting range: 0 day–30 days, with a step of 1 day, but only available for flooded lead-acid batteries, sealed lead-acid batteries, and user-defined ones
21	Equalizing charge Enable/Disable	DIS (default)	Start equalizing charge immediately
		ENA	Stop equalizing charge immediately

ID	Parameter	Option	Description
22	Energy-saving mode	DIS (default)	Disable energy-saving mode
		ENA	Enable energy-saving mode, and when the load power is below 50 W, it will turn off the inverter output after a 5-minute delay. When it exceeds 50 W, the inverter will automatically restart.
23	Overload auto restart	DIS	Disable overload auto restart and when overload occurs, it will turn off the output and the inverter will no longer resume startup
		ENA (default)	Enable overload auto restart, and If overload occurs, the output will be turned off, and after a delay of 3 min, the output will restart. After 5 cumulative attempts, the inverter will no longer resume startup
24	Over-temperature auto restart	DIS	Disable over-temperature auto restart and when over-temperature occurs, it will turn off the output and the inverter will no longer turn on the output
		ENA (default)	Enable over-temperature auto restart and when over-temperature occurs, it will turn off the output and the output will restart when the temperature drops
25	Buzzer alarm	DIS	Disable buzzer alarm
		ENA (default)	Enable buzzer alarm
26	Mode switch prompt	DIS	Disable prompt when the status of the main input source changes
		ENA (default)	Enable prompt when the status of the main input source changes
27	Inverter to bypass switch	DIS	Disable auto switch to mains for loading in case of inverter overload
		ENA (default)	Enable auto switch to mains for loading in case of inverter overload
28	Mains charge current	60 (default)	SPI-8K-UP, setting range: 0 A–100 A
			SPI-10K-UP, setting range: 0 A–120 A
30	RS485 communication address	ID: 1	Setting range: 1–254
31	Parallel mode (turn off the rocker switch can be set)	SIG (default)	Single inverter operation
		PAL	Parallel operation
		2P0/2P1/2P2	Two-phase parallel operation
		Set to "2P0" for the machine screens connected to P1 Assuming that the output voltage of the setting item [38] is set to 120 VAC 1) When all the inverters connected to P2 are set to "2P1" on the screen, the voltage phase difference between P1 and P2 is 120°, the voltage between the live wire L1 of phase-P1 and the live wire L2 of phase-P2 is $120 \times 1.732 = 208$ VAC, and the voltage of L1-N and L2-N is 120 VAC. 2) When all the inverters connected to P2 are set to "2P2" on the screen, the	

ID	Parameter	Option	Description
			voltage phase difference between P1 and P2 is 180°, the voltage between the live wire L1 of phase-P1 and the live wire L2 of phase-P2 is $120 \times 2 = 240$ VAC, and the voltage of L1-N and L2-N is 120 VAC.
		3P1/3P2/3P3	Three-phase parallel operation
			Set to "3P1" on the screen for all the inverters connected to P1; set to "3P2" on the screen for all the inverters connected to P2; and set to "3P3" on the screen for those connected to P3. 1) Assuming that the output voltage of the setting item [38] is set to 120 VAC: then the voltage phase difference of P1-P2, P1-P3, and P2-P3 is 120°, the voltage between the live wire L1 of phase-P1 and the live wire L2 of phase-P2 is $120 \times 1.732 = 208$ VAC, and similarly the voltage of L1-L3 and L2-L3 is 208 VAC; the voltage of L1-N, L2-N, and L3-N is 120 VAC.
32	RS485 communication function	SLA (default)	Enable PC and Remote Monitoring Protocol
		485	Enable the BMS communication function based on RS485 communication
		CAN	Enable the BMS communication function based on CAN communication
33	BMS communication		Select the corresponding communication protocol in item 33 when you set it to 485 or CAN in item 32
			PAC = PACE, RDA = Ruida, AOG = Aoguan, OLT = Oliter, HWD = Sunwoda, DAQ = Daqin, WOW = SRNE, PYL = Pylontech, UOL = Vilion
35	Battery under-voltage recovery threshold	52	When the battery is under voltage, the battery voltage needs to be greater than the threshold to restore the AC output of the battery inverter. Setting range: 44 V–54.4 V
37	Recharge voltage threshold for fully charged battery	52	After the battery is fully charged, the inverter stops charging, and recovers charging when the battery voltage is lower than the threshold. Setting range: 44 V–54 V
38	AC output voltage (turn off the rocker switch can be set)	120	Setting range: 100/105/110/115/120/127 VAC The rated output power will be reduced= (Power Rate)*(Vset/120)
39	Charge current limit (when BMS works)	LCSET	The maximum battery charge current is not greater than the set value of [item 07]
		LCBMS (default)	The maximum battery charge current is not greater than the maximum value of BMS
		LCINV	The maximum battery charge current is not greater than the logical judgment value of inverter
40	Period-1 battery charge start time	00:00:00	Setting range: 00:00:00–23:59:00
41	Period-1 battery charge end time	00:00:00	Setting range: 00:00:00–23:59:00
42	Period-2 battery	00:00:00	Setting range: 00:00:00–23:59:00

ID	Parameter	Option	Description
	charge start time		
43	Period-2 battery charge end time	00:00:00	Setting range: 00:00:00–23:59:00
44	Period-3 battery charge start time	00:00:00	Setting range: 00:00:00–23:59:00
45	Period-3 battery charge end time	00:00:00	Setting range: 00:00:00–23:59:00
46	Timed battery charge function	DIS (default)	Disable the function
		ENA	After the timed mains charge/loading function is enabled, the power supply mode will turn into SBU, where mains is available for power supply in the set period or after battery over-discharge. If the timed discharge function is enabled at the same time, the power supply mode of the system will be changed into UTI, where mains is only available for power supply in the set charge period, and the system only switches to the power supply of battery inverter during the set discharge period or mains failure
47	Period-1 battery discharge start time	00:00:00	Setting range: 00:00:00–23:59:00
48	Period-1 battery discharge end time	00:00:00	Setting range: 00:00:00–23:59:00
49	Period-2 battery discharge start time	00:00:00	Setting range: 00:00:00–23:59:00
50	Period-2 battery discharge end time	00:00:00	Setting range: 00:00:00–23:59:00
51	Period-3 battery discharge start time	00:00:00	Setting range: 00:00:00–23:59:00
52	Period-3 battery discharge end time	00:00:00	Setting range: 00:00:00–23:59:00
53	Timed battery discharge function	DIS (default)	Disable the function
		ENA	After the timed battery discharge function is enabled, the power supply mode will be changed into UTI, where the system only switches to the power supply of battery inverter during the set discharge period or mains failure
54	Current date	00:00:00	Year/Month/Day Setting range: 00:01:01–99:12:31
55	Current time	00:00:00	Setting range: 00:00:00–23:59:59
57	Charge stop	3	The charge stops when the charge current is less than the set

ID	Parameter	Option	Description
	current		value (unit: A)
58	SOC setting for discharge alarming	15	When the capacity is less than the set value, the SOC alarms (unit: %, only available during normal BMS communication)
59	SOC setting for discharge cutoff	5	When the capacity is less than the set value, the discharge stops (unit: %, only available during normal BMS communication)
60	SOC setting for charge cutoff	100	When the capacity is greater than the set value, the charge stops (unit: %, only valid during normal BMS communication)
61	SOC setting for switching to mains	10	When the capacity is less than the set value, it switches to mains (unit: %, only available during normal BMS communication)
62	SOC setting for switching to inverter output	100	When the capacity is greater than the set value, it switches to the inverter output mode (unit: %, only available during normal BMS communication)
63	Auto N-PE connection switch function	DIS (default)	Disable auto N-PE connection switch
		ENA	Enable auto N-PE connection switch
68	AC output phase mode (turn off the rocker switch can be set)	0	0 represents the single-phase mode Assuming that the AC output voltage of item 38 is 120 V, the phase difference of L1-L2 is 0°, and L1/L2 can be connected in parallel, the phase voltage of L1-N/L2-N is 120 V
		180 (default)	180 represents the split-phase mode Assuming that the AC output voltage of item 38 is 120 V, the phase difference of L1-L2 is 180°, the phase voltage of L1-N/L2-N is 120 V, and the voltage of L1-L2 is 240 V
		NO N	Without N-wire(When you set " No N" ,the phase difference is 180° default)

5.3 AC output mode

The AC output mode corresponds to parameter setting items of 01 and 34, allowing users' manual setting

- **Mains first 01 UTI (default)**

The mains first supplies power. When PV is available, mains and PV can supply power to the load at the same time. The battery only powers the load during unavailable mains (**priority: mains > PV > battery**).

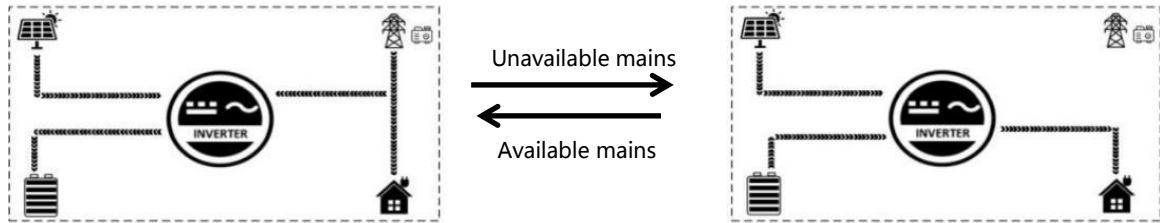

- **Mix loading of PV and mains**

In the UTI mode, when the battery is not connected, or fully charged, PV and mains supply power to the load at the same time (**priority: PV > mains > battery**).



- **PV-first output 01 SOL**

PV first supplies power to the load. If PV power is insufficient, mains is used as a supplement to power the load. The mode uses PV power to the maximum extent while maintaining the battery power, suitable for areas with relatively stable power grids. (**Priority: PV > mains > battery**).

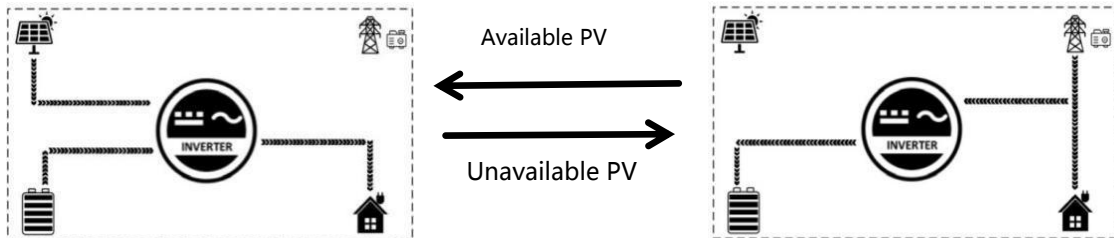

- **Inverter output mode 01 SBU**

PV will first supply power to the load. If PV power is insufficient or unavailable, mains will be used as a supplement to power the load. When the battery voltage reaches the value of the parameter item 04 (battery to mains voltage threshold), it will switch to mains to power the load. The mode maximizes the use of DC power, suitable for areas with suitable power grids. (**Priority: PV > battery > mains**).

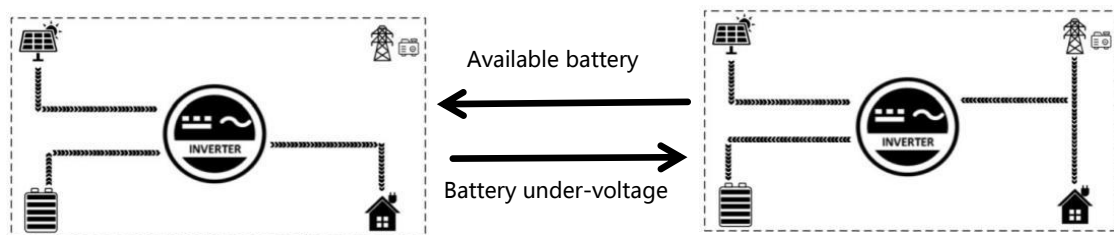

5.4 Battery charge mode

The charge mode corresponds to the parameter setting item 06, allowing users' manual setting.

- **Mix charge SNU (default)**

Both PV and mains charge the battery, with PV used first, and mains as a supplement during insufficient PV power. This is the fastest charge method, suitable to provide users with sufficient backup power in areas where the power supply is insufficient. (**Priority: PV > mains**).

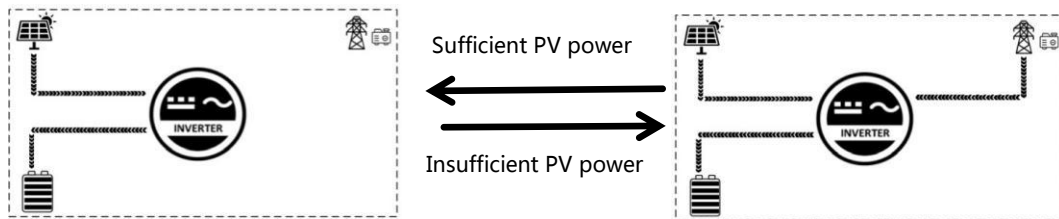

- **Only-PV charge OSO**

Only PV power is used to charge the battery, with mains not used for charge. This is the most energy-saving method, by which the battery power comes from solar energy, usually used in areas with good radiation conditions.

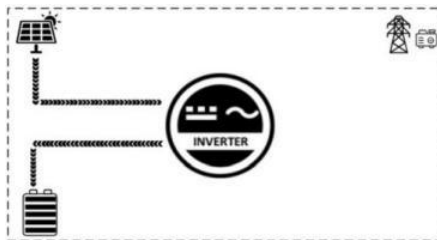

5.5 Timed charge/discharge function

SPI series has the timed power charge/discharge function. Users can set different charge and discharge periods according to the local time-of-use price, thus reasonably using mains and PV power. When mains is expensive, the battery inverter is used to supply power to the load; when mains is cheap, it can be used to supply power to and charge the load, thus helping users reduce electricity expenses to the full extent. Users can turn on/off the timed charge/discharge function in items 46 and 53 in the setup menu, and set charge and discharge periods in parameters 40–45 and 47–52.

The following is an example to help users understand the function.

Before using the function for the first time, please set the local time and date in parameters 54 and 55, and then you can set corresponding periods based on the local time-of-use price.

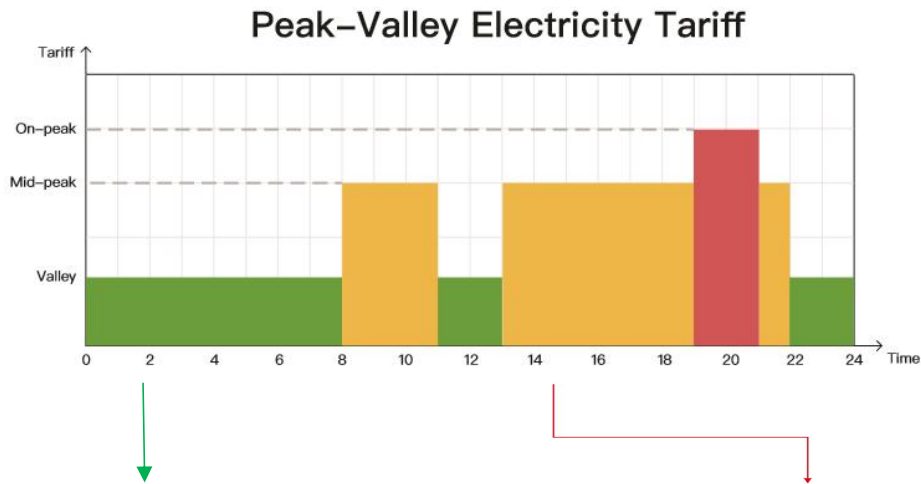

Timed charge and loading function



With 3 definable periods, users can freely set the mains charge/loading period in the range of 00:00–23:59. During the period set by the user, in case of PV energy output, it will be used first; in case of no PV energy output or lack of PV energy, mains will be used as a supplement.

Timed battery discharge function



With 3 definable periods, users can freely set the battery discharge period in the range of 00:00–23:59. During the period set by the user, the inverter will first use the battery inverter to load; if the battery power is insufficient, the inverter will automatically switch to mains to ensure stable operation of the load.

5.6 Battery parameters

- **Lead-acid battery**

Parameter/Battery Type	Sealed Lead-acid Battery	Gel lead-acid battery	Flooded Lead-acid Battery	User-defined Battery
	SLD	GEL	FLD	USE
Overvoltage disconnect voltage	60 V	60 V	60 V	60 V
Equalizing charge voltage	58 V	56.8 V	58 V	40 V–60 V (settable)
Boost charge voltage	57.6 V	56.8 V	57.6 V	40 V–60 V (settable)
Floating charge voltage	55.2 V	55.2 V	55.2 V	40 V–60 V (settable)

Under-voltage alarm voltage	44 V	44 V	44 V	40 V–60 V (settable)
Under-voltage disconnect voltage	42 V	42 V	42 V	40 V–60 V (settable)
Discharge limit voltage	40 V	40 V	40 V	40 V–60 V (settable)
Over-discharge delay time	5s	5s	5s	1s–30s (settable)
Equalizing charge duration	120 min	-	120 min	0 min–900 min (settable)
Equalizing charge cycle	30 d	-	30 d	0 d–250 d (settable)
Boost charge cycle	120 min	120 min	120 min	10 min–900 min (settable)

- Li-ion battery**

Parameter/Battery Type	Ternary Li-ion Battery		LFP Battery			User-defined Battery
	N13	N14	L16	L15	L14	USE
Overvoltage disconnect voltage	60 V	60 V	60 V	60 V	60 V	60 V
Equalizing charge voltage	-	-	-	-	-	40 V–60 V (settable)
Boost charge voltage	53.2 V	57.6 V	56.8 V	53.2 V	49.2 V	40 V–60 V (settable)
Floating charge voltage	53.2 V	57.6 V	56.8 V	53.2 V	49.2 V	40 V–60 V (settable)
Under-voltage alarm voltage	43.6 V	46.8 V	49.6 V	46.4 V	43.2 V	40 V–60 V (settable)
Under-voltage disconnect voltage	38.8 V	42 V	48.8 V	45.6 V	42 V	40 V–60 V (settable)
Discharge limit voltage	36.4 V	39.2 V	46.4 V	43.6 V	40.8 V	40 V–60 V (settable)
Over-discharge delay time	30s	30s	30s	30s	30s	1s–30s (settable)
Equalizing charge duration	-	-	-	-	-	0 min–900 min (settable)
Equalizing charge cycle	-	-	-	-	-	0 d–250 d (settable)
Boost charge cycle	120 min (settable)	120 min (settable)	120 min (settable)	120 min (settable)	120 min (settable)	10 min–900 min (settable)

6. Communication

6.1 Overview

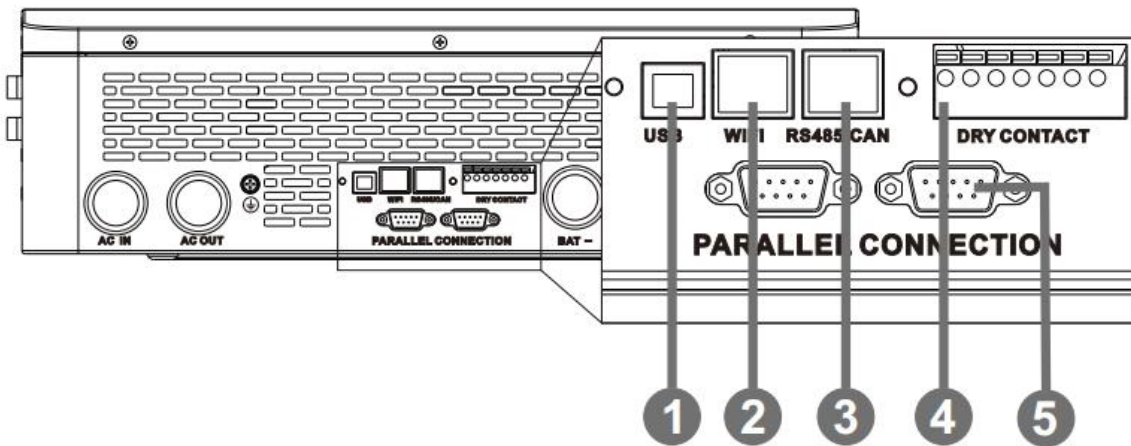

1	USB-B port	2	WIFI port	3	RS485/CAN port
4	Dry contact port	5	Parallel port		

6.2 USB-B port

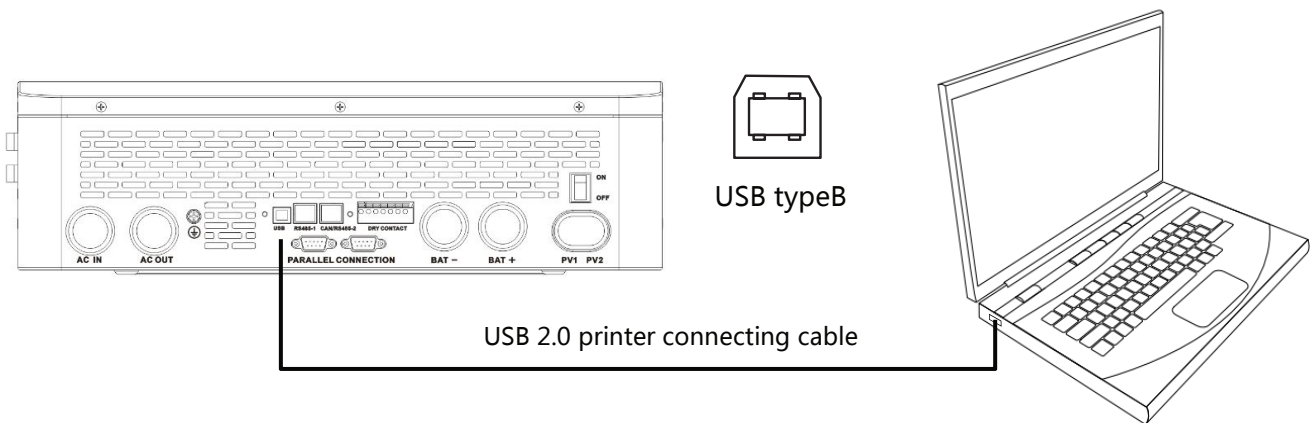

Users can use the upper computer software through the port to read and modify device parameters. If needing the installation package for the upper computer software, you can download it from the official website of SRNE, or contact us to get it.

6.3 WIFI port

The WIFI port is used to connect to the Wi-Fi/GPRS data acquisition module, and then users can view the operation status and parameters of the inverter via the mobile APP.

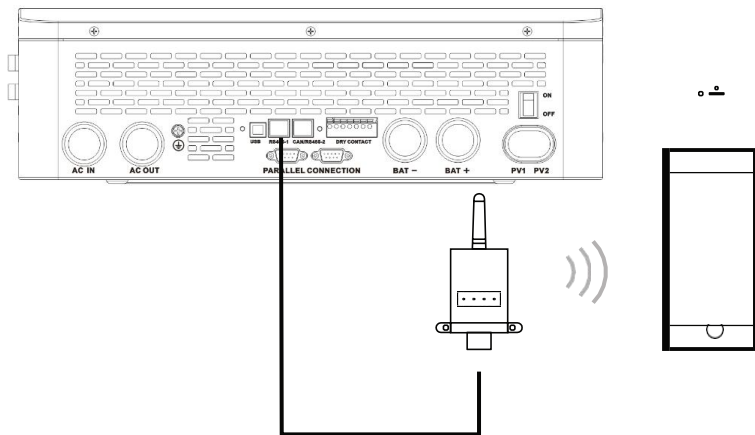

RJ45	Definition
Pin 1	5 V
Pin 2	GND
Pin 3	/
Pin 4	/
Pin 5	/
Pin 6	/
Pin 7	RS485-A
Pin 8	RS485-B

6.4 RS485/CAN port

The RS485/CAN port is used to connect to the BMS of the Li-ion battery.

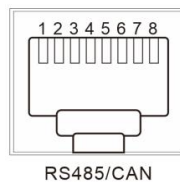

NOTICE

If you need the communication between the inverter and the BMS of the Li-ion battery, please contact us to understand the communication protocol, or upgrade the inverter to the corresponding software program.

RJ45	Definition
Pin 1	RS485-B
Pin 2	RS485-A
Pin 3	/
Pin 4	CANH
Pin 5	CANL
Pin 6	/
Pin 7	RS485-A
Pin 8	RS485-B

6.5 Dry contact port

The dry contact port has 4 functions:

1. Remote ON/OFF
2. ON/OFF signal output
3. Battery temperature sampling
4. Remote generator start/stop

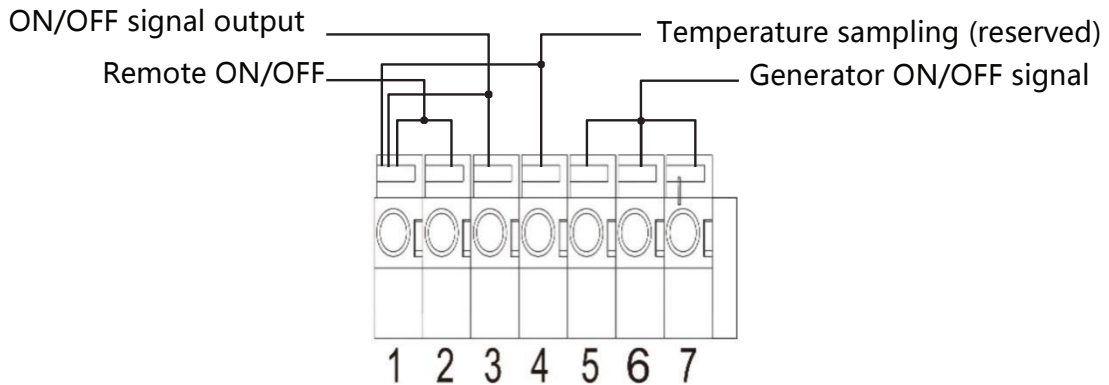

Function	Description
Remote ON/OFF (reserved)	When pin 1 is connected to pin 2, the inverter will turn off the AC output. When disconnected, the inverter is in normal output.
ON/OFF signal output (reserved)	When the battery voltage reaches the discharge limit voltage (parameter 15), the voltage between pin 3 and pin 1 is 0 V. When the battery is in normal charge or discharge status, the voltage between pin 3 and pin 1 is 5 V.
Temperature sampling (reserved)	Pins 1 and 4 can be used for battery temperature sampling compensation.
Remote generator start/stop	When the battery voltage reaches the under-voltage alarm voltage (parameter 14) or the voltage threshold for mains to switch to the battery (parameter 04), pins 6 to 5 are normally open, and pins 7 to 5 are normally closed. When the battery voltage reaches the voltage threshold for the battery to switch to mains (parameter 05), or the battery is fully charged, pins 6 to 5 are normally closed, and pins 7 to 5 are normally open. (5/6/7 pin output: 125 VAC/1 A, 230 VAC/1 A, and 30 VDC/1 A)

NOTICE

- If you need to use the remote start/stop function of the generator with dry contact, please ensure that the generator has an ATS and supports remote start/stop.

7. Fault Codes and Response Measures

7.1 Fault codes

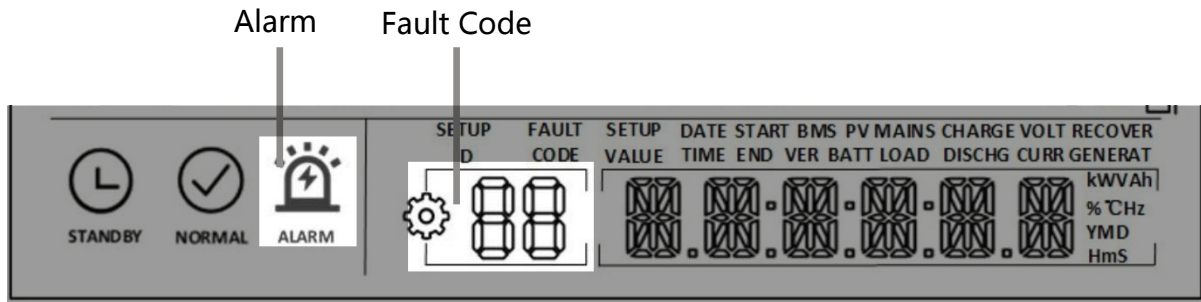

Fault Code	Meaning	Affect Output or Not	Description
01	BatVoltLow	Yes	Battery under-voltage alarm
02	BatOverCurrSw	Yes	Overcurrent software protection for average battery discharge current
03	BatOpen	Yes	Disconnected battery alarm
04	BatLowEod	Yes	Under-voltage battery discharge stop alarm
05	BatOverCurrHw	Yes	Battery overcurrent hardware protection
06	BatOverVolt	Yes	Charge overvoltage protection
07	BusOverVoltHw	Yes	Bus overvoltage hardware protection
08	BusOverVoltSw	Yes	Bus overvoltage software protection
09	PvVoltHigh	Yes	PV overvoltage protection
10	PvBoostOCSw	No	Boost overcurrent software protection
11	PvBoostOCHw	No	Boost overcurrent hardware protection
12	SpiCommErr	Yes	SPI communication fault of master and slave chips
13	OverloadBypass	Yes	Bypass overload protection
14	OverloadInverter	Yes	Inverter overload protection
15	AcOverCurrHw	Yes	Inverter overcurrent hardware protection
16	AuxDspReqOffPWM	Yes	Slave chip OFF request fault
17	InvShort	Yes	Inverter short-circuit protection
18	Bussoftfailed	Yes	Bus soft-start failure
19	OverTemperMppt	No	PV heat sink over-temperature protection
20	OverTemperInv	Yes	Inverter heat sink over-temperature protection
21	FanFail	Yes	Fan fault
22	EEPROM	Yes	Memory fault
23	ModelNumErr	Yes	Model setting error
24	Busdiff	Yes	Positive and negative bus voltage imbalance
25	BusShort	Yes	Bus short-circuit

26	Rlyshort	Yes	Inverter AC output backward to bypass AC output
28	LinePhaseErr	Yes	Mains input phase error
29	BusVoltLow	Yes	Bus low-voltage protection
30	BatCapacityLow1	Yes	Alarm of battery capacity rate below 10% (taking effect after BMS communication is successful)
31	BatCapacityLow2	No	Alarm of battery capacity rate below 5% (taking effect after BMS communication is successful)
32	BatCapacityLowStop	Yes	Battery low-capacity OFF (taking effect after BMS communication is successful)
34	CanCommFault	Yes	Parallel can communication fault
35	ParaAddrErr	Yes	Parallel ID (communication address) setting error
37	ParaShareCurrErr	Yes	Parallel current sharing fault
38	ParaBattVoltDiff	Yes	Large battery voltage difference in parallel mode
39	ParaAcSrcDiff	Yes	Inconsistent mains input source in parallel mode
40	ParaHwSynErr	Yes	Hardware synchronization signal error in parallel mode
41	InvDcVoltErr	Yes	Inverter DC voltage error
42	SysFwVersionDiff	Yes	Inconsistent system firmware version in parallel mode
43	ParaLineContErr	Yes	Parallel connection fault
44	Serialnumbererror	Yes	Failure to set the serial number before leaving factory
45	Errorsettingofsplit-phasemode	Yes	Setting error of setting items in parallel mode
56	Lowinsulationresistancefault	No	Abnormally low earth impedance of PV1+, PV2+, and PV-
57	Leakagecurrentoverloadfault	Yes	System current leakage out of the standard
58	BMSComErr	No	BMS communication fault
60	BMSUnderTem	No	BMS under-temperature alarm (taking effect after BMS communication is successful)
61	BMSOverTem	No	BMS over-temperature alarm (taking effect after BMS communication is successful)
62	BMSOverCur	No	BMS overcurrent alarm (taking effect after BMS communication is successful)
63	BMSUnderVolt	No	BMS under-voltage alarm (taking effect after BMS communication is successful)
64	BMSOverVolt	No	BMS overvoltage alarm (taking effect after BMS communication is successful)

7.2 Troubleshooting

Fault Code	Meaning	Cause	Solution
/	No screen display	There is no power input, or the device switch at its bottom is not turned on	Check if the battery air-switch or PV air-switch has been closed; check if the switch is in "ON"; press any button on the screen to exit the screen sleep mode.
01	Battery under-voltage	The battery voltage is lower than the value set in parameter [14]	Charge the battery until the battery voltage exceeds the value set in parameter [14].
03	Disconnected battery	The battery is not connected, or the BMS of the lithium-ion battery is in the discharge protection state	Check if the battery is reliably connected; check if the circuit breaker of the battery is off; ensure that the BMS of the lithium-ion battery can communicate normally.
04	Battery over-discharge	The battery voltage is lower than the value set in parameter 12	Manual reset: Turn off the power, and restart Automatic reset: Charge the battery until the battery voltage is higher than the value set in parameter [35]
06	Rechargeable battery overvoltage protection	The battery is in the overvoltage state	Manually turn off the power, and restart Check if the battery voltage exceeds the limit. If the limit is exceeded, discharge the battery until the voltage is below the overvoltage recovery threshold of the battery
13	Bypass overload (software detection)	The output power or current of the bypass is overloaded within a certain period	Reduce the load power, and restart the device. For more details, please refer to item 11 in <i>Protection Function</i>
14	Inverter overload (software detection)	The output power or current of the inverter is overloaded within a certain period	
19	Over-high temperature of the heat sink for PV input (software detection)	The temperature of the heat sink for PV input exceeds 90°C for 3s	Wait until the temperature of the heat sink is below the over-temperature recovery temperature, when charge and discharge return to normal
20	Over-high temperature of the heat sink for inverter output (software detection)	The temperature of the heat sink for inverter output exceeds 90°C for 3s	

21	Fan fault	Software detection finds the fan has a fault	Shut down, manually flick the fan, and check if any foreign objects are blocking it
26	AC input relay short-circuit	Stuck relay for AC output	Manually shut down, and restart. If the fault occurs again after restarting, contact the after-sales service personnel to repair the machine
28	Mains input phase fault	The phase of AC input is inconsistent with that of AC output	Ensure that the phase of AC input is the same as that of AC output. For example, if the output is in the split-phase mode, the input shall also be in the split-phase mode.

① NOTICE

If you encounter product faults that cannot be solved by the methods listed in the above table, please contact our after-sales service department for technical support, and do not disassemble the device by yourself.

8. Protection Function and Product Maintenance

8.1 Protection function

No.	Protection Function	Description
1	PV current-limiting protection	When the charge current or power of the configured PV array exceeds the rated current and power of the inverter, it will charge at the rated current and power
2	PV overvoltage protection	If the PV voltage exceeds the maximum allowable value of hardware, the machine will report the fault, and stop the step-up of PV to output sine AC waves
3	Reverse charge protection at night	At night, as the battery voltage is greater than that of the PV module, it will prevent the battery from discharging to the PV module
4	mains input overvoltage protection	When the mains voltage of each phase exceeds 140 VAC, it will stop mains from charging, and switch it to inverter output
5	Mains input under-voltage protection	When the mains voltage of each phase is lower than 90 VAC, it will stop mains from charge, and switch it to inverter output
6	Battery overvoltage protection	When the battery voltage reaches the overvoltage disconnect voltage threshold, it will automatically stop PV and mains from charging the battery, thus preventing damage to the battery due to overcharge

7	Battery under-voltage protection	When the battery voltage reaches the low-voltage disconnect voltage threshold, it will automatically stop discharging the battery, thus preventing damage to the battery due to overdischarge
8	Battery overcurrent protection	When the battery current exceeds the allowable range of hardware, the machine will turn off the output, and stop discharging the battery
9	AC output short-circuit protection	When a short-circuit fault occurs at the load output terminal, it will immediately turn off the output of AC voltage. Only after manually powering on the device, normal output restores
10	Heat sink over-temperature protection	When the internal temperature of the inverter is too high, the inverter will stop charging and discharging; when the temperature returns to normal, the inverter will charge and discharge again
11	Overload protection	After overload protection is triggered, the inverter output will be restored after 3 min, and after 5 times of overload, the output will be off until the frequency changer is restarted. (102% < load < 110%): An error will be reported, and the output will be turned off after 5 min. (110% < load < 125%): An error will be reported, and the output will be turned off after 10s. Load > 125%: An error will be reported, and the output will be turned off after 5s.
12	AC backward protection	Prevent the mains of battery inverter backward to bypass AC input
13	Bypass overcurrent protection	Built-in circuit breaker for AC input overcurrent protection
14	Bypass wiring error protection	When the phase of the two bypass inputs is different from that of the inverter split-phase, the machine will prohibit connecting to the bypass, thus preventing the power failure or short circuit of load when connecting to the bypass

8.2 Maintenance

In order to maintain the best long-term performance, it is recommended to conduct following checks twice a year.

1. Make sure that the airflow around the inverter is smooth, and remove any dirt or debris from the heat sink.
2. Check whether the insulation of all exposed wires is damaged by exposure to sunlight, friction with other objects around them, dryness, bite by insects or rodents, etc. Repair or replace wires if necessary.
3. Verify the consistency of the indication and display with the device operation. Please pay attention to any faults or errors, and take corrective actions if necessary.
4. Check all wiring terminals for corrosion, insulation damage, and signs of high temperature or burning/discoloration, and tighten the terminal screws.
5. Check for dirt, nesting insects, and corrosion, clean up as required, and clean the insectproof net regularly.
6. If the arrester fails, replace it in time against lightning damage to the inverter or even other devices of the user.

DANGER

- Before conducting any inspection or operation, please ensure that the inverter is disconnected from all power sources and that the capacitor is fully discharged to avoid the risk of electric shock.

Our company will not be held responsible for damage due to the following reasons:

1. Damage caused by improper use or use in the wrong location.
2. The open circuit voltage of the PV module exceeds the maximum allowable voltage.
3. The operating temperature exceeds the limited operating temperature range.
4. Unauthorized personnel dismantle, and repair the inverter.
5. Force majeure: damage during transportation or handling of the inverter

9. Parameter Table

Inverter Model	SPI-8K-UP	SPI-10K-UP	Settable
Inverter output			
Rated Output Power	8,000 W	10,000 W	
Max. Peak Power	16,000 W	20,000 W	
Rated Output Voltage	120/240 VAC (single-phase/split-phase)		Y
Loading Motor Capacity	5 HP	6 HP	
Rated Frequency	50/60 Hz		Y
Output Wave	Pure sine wave		
Switching Time	10 ms (typical value)		
Parallel Number	6		
Overload Protection	<p>After overload protection is enabled, the inverter output will be restored after 3 min, and after 5 times of overload, the output will be off until the inverter is restarted.</p> <p>(102% < load < 110%): An error will be reported, and the output will be turned off after 5 min.</p> <p>(110% < load < 125%): An error will be reported, and the output will be turned off after 10s.</p> <p>Load > 125%: An error will be reported, and the output will be turned off after 5s.</p>		
Battery			
Battery Type	Lithium-ion battery/lead-acid battery/user-defined battery		Y
Rated Battery Voltage	48 Vdc		
Voltage Range	40 Vdc–60 Vdc		Y
Max. PV Charge Current	180 A	200 A	Y
Max. Grid/Generator Charge Current	100 A	120 A	Y
Max. Hybrid Charging Current	180 A	200 A	Y
PV Input			
No. of MPPT Trackers	2		
Max. Input Power	11,000 W		
Max. Input Current	22/22 A		
Max. Open Circuit Voltage	500 Vdc		
MPPT Operating Voltage Range	125 Vdc–425 Vdc		
Mains/generator input			
Input Voltage Range	90 VAC–140 VAC		
Input Frequency Range	50/60 Hz		

Bypass Overload Current	63 A	
Efficiency		
MPPT Tracking Efficiency	99.9%	
Max. Efficiency of Battery	92%	
General		
Dimension	620 mm*445 mm*130 mm	
Weight	27 kg	
Protection level	IP20, for indoor use only	
Ambient temperature	-10°C-55°C, >45°C derating	
Noise	<60 dB	
Cooling mode	Intelligent fan	
Communication		
Built-in interface	RS485/CAN/USB/dry contact	Y
External module (optional)	Wi-Fi/GPRS	Y
Certification		
Safety	IEC62109-1, IEC62109-2, and UL1741	
EMC	EN61000-6-1, EN61000-6-3, and FCC 15 class B	
RoHS	Yes	

